



RULES AND REGULATIONS

SAMPLES, SOUVENIRS, ETC.

The distribution of samples and souvenirs is permitted provided there is no interference with other exhibitors and the giveaways pertain to the Medical and/or Health Care profession. If you have questions about what is permitted for giveaways on the show floor, please email Taylor Hill-Tout, Operations Manager at thill-tout@pri-med.com to discuss your ideas prior to purchase. Animals are not allowed on the show floor without prior approval. All distribution of handouts, souvenirs, promotional literature, etc. must be done from your booth. If you are a Pharmaceutical Company, it is your responsibility to ensure that your exhibit and distributions are in accordance with all relevant industry regulations (PhRMA Code on Interactions with Healthcare Professionals and AdvaMed Code of Ethics on Interactions with Healthcare Professionals), federal regulations (Department of Health and Human Services, Office of the Inspector General Compliance Program Guidance for Pharmaceutical Manufactures and the FDA Guidance on Industry Supported Scientific and Educational Activities). In addition, all companies must adhere to the AMA Code of Medical Ethics on Gifts to Physicians.

For further information, please visit the following websites:

AMA guidelines: <http://www.ama-assn.org/ama/pub/category/13497.html>

Pharma guidelines:
<http://www.phrma.org/>

NO SMOKING POLICY

There is no smoking allowed anywhere in the Boston Convention & Exhibition Center.

CROWD CONTROL

It is the exhibitor's responsibility to arrange displays and product giveaway presentations in a manner which ensures all personnel and attendees are within the contracted space, and not encroaching on the aisle or neighboring booths. Exhibitor personnel must manage this onsite. This will be strictly enforced.

BALLOONS

Balloons are strictly prohibited by show management.

PORTER SERVICE (TRASH REMOVAL)

If an exhibitor is distributing samples or souvenirs, which can create excess trash in public space, they are required to make arrangements for porter service. Storing trash in the aisles is prohibited. Porter service can be ordered by the hour, half hour, or on continual service. Please contact Freeman Exhibitor Services to set up the service appropriate to your booths' needs.

PRODUCT TESTING AND EXHIBITOR DEMONSTRATION

All X-Ray machines that will be operated in the exhibit hall must be approved by the Exhibitor Services Specialist.

Demonstrations that affect the quality of the show due to unpleasant odors or noise violations will be monitored. Show Management has the right to ask that a demonstration be stopped if there is a reasonable disturbance.

SOLICITING

It is against Pri-Med policy to solicit a crowd in any manner outside of the facility. Any acts of solicitation found will be taken seriously and may result in the loss of priority points.



SOUND/MUSIC

In general, exhibitors may use sound equipment in their booths so long as the noise level does not disrupt the activities of neighboring exhibitors. Speakers and other sound devices should be positioned so as to direct sound into the booth rather than into the aisle. Rule of thumb: Sound and noise should not exceed 85 decibels.

Exhibitors should be aware that music played in their booths, whether live or recorded, may be subject to laws governing the use of copyrighted compositions. ASCAP, BMI and SESAC are three authorized licensing organizations that collect copyright fees on behalf of composers and publishers of music.

SYMPOSIA & PRESENTATION THEATER POLICY

Please be advised that direct promotion of symposia & presentation theaters is strictly prohibited in an exhibit booth on the tradeshow floor. Symposia & presentation theaters sessions are ticketed events with limited seating and are available on a first come, first served basis. It is imperative that exhibitors do not promise a seat/ticket for a symposium or presentation theater to a non-registered attendee on-site. If an attendee has not received a ticket, they may visit the attendee registration counters for an update on availability.

BOOTH DESIGN & BUILD

EQUIPMENT REMOVAL FROM THE EXHIBIT HALL

To reduce the occurrence of theft, we would like to discourage exhibitors from hand carrying materials out of the exhibit halls. Security will stop anyone hand carrying materials out of the exhibit hall and ask for a "Property Pass." These passes can be obtained in the show office.

AMERICANS WITH DISABILITIES ACT (ADA)

All exhibiting companies are required to be in compliance with the Americans with Disabilities Act (ADA) and are encouraged to be sensitive, and as reasonably accommodating as possible, to attendees with disabilities.

Information regarding ADA compliance is available from the U.S. Department of Justice ADA Information Line (800-514-0301) and from web site www.usdoj.gov/crt/ada/infoline.htm.

TEAR-DOWN

Dismantling or tearing down an exhibit early, or leaving your booth unattended is prohibited for the following reasons:

- It is unfair to attendees who plan to visit booths until the close of the show.
- It is unfair to neighboring exhibitors.
- It hurts the integrity of the show.

If you begin dismantling your booth prior to the official closing hour of the exhibition, it can result in the loss of priority points and/or the refusal by Show Management to accept or process future exhibit space applications.

Therefore, all exhibits must remain fully intact and staffed until the exhibition has officially ended.



STORAGE

Fire regulations in most exhibit facilities prohibit storing product, literature, empty packing containers or packing materials behind back drapes or under draped tables. In most cases, however, exhibitors may store a limited supply of literature or product appropriately within the booth area, so long as these items do not impede access to utility services, create a safety problem or look unsightly. Corner booths will be required to drape any unsightly areas behind the booth at their own expense.

CARPET OR FLOOR COVERING

****REQUIRED****

Exhibitors are required to cover their entire booth space. Exhibitors are entitled to bring in their own floor covering, or they can rent carpet from Freeman. If an exhibitor in an island booth does not have their carpet line up with the aisle carpet, causing the facility floor to show, aisle carpet will be used to fill in any gap that may exist. The "cut and lay" for this fill in will occur at the exhibitor's expense.

STRUCTURAL INTEGRITY

All exhibit displays should be designed and erected in a manner that will withstand normal contact or vibration caused by neighboring exhibitors, hall laborers or installation/dismantling equipment such as forklifts. Displays should also be able to withstand moderate wind effects that may occur in the exhibit hall when freight doors are open. Refer to local building codes that regulate temporary structures. Exhibitors should ensure that any display fixtures such as tables, racks, or shelves are designed and installed properly to support the product or marketing materials to be displayed upon them.

FLAMMABLE AND TOXIC MATERIALS

All materials used in display construction or decorating should be made of fire retardant materials and be certified as flame retardant. Samples should also be available for testing. Materials that cannot be treated to meet the requirements should not be used. A flame-proofing certificate should be available for inspection. Exhibitors should dispose of any waste products they generate during the exhibition in accordance with guidelines established by the Environmental Protection Agency and the facility.

ELECTRICAL

Every exhibit facility has different electrical requirements; however, minimum guidelines are suggested:

- All 100-volt wiring should be grounded three-wire.
- Wiring that touches the floor should be "SO" cord (minimum 14-gauge/three-wire) flat cord, which is insulated to qualify for "extra hard usage".
- Cord wiring above floor level can be "SJ" which is rated for "hard usage".
- Using zip cords, two-wire cords, latex cords, plastic cord, lamp cord, open clip sockets, and two-wire clamp on fixtures is not recommended and is often prohibited. Cube taps are not recommended and are often prohibited.
- Power Strips (multi-plug connectors) should be UL approved, with the built-in over load protectors.



LIGHTING

Exhibitors should adhere to the following suggested minimum guidelines when determining booth lighting:

- No lighting, fixtures, lighting trusses or overhead lighting are allowed outside the boundaries of the exhibit space. Exhibitors intending to use hanging light systems should submit drawing to exhibition management for approval.
- Lighting should be directed to the inner confines of the booth space. Lighting should not project into other exhibits or show aisles.
- Lighting which is potentially harmful, such as lasers or ultraviolet lighting, should comply with facility rules and be approved in writing by exhibition management.
- Lighting that spins, rotates, pulsates and other specialized lighting effects should be in good taste and not interfere with neighboring exhibitors or otherwise detract from the general atmosphere of the event.

Pri-Med East | Approved Vendors

In order to maintain the quality of services offered to our exhibitors, Pri-Med Show Management has verified the qualifications of the firms supplying support services. Forms and additional information are included in the Service Manual.



Venue

Boston Convention and Exhibition Center
415 Summer St
Boston, MA 02210
(P): 617-954-2000



Security

Massachusetts Convention Center Authority
415 Summer St
Boston, MA 02210
(P): 617-954-2230
(E): exhibitorservices@signatureboston.com



General Contractor

Freeman
275 Bodwell Street
Avon, MA 02322
(P): 508-894-5100



Hotels

OnPeak
OnPeak
(P): 800-584-9017
(E): primed@onpeak.com



Audio Visual

Ovation
1138 Second Ave. N
Nashville, TN 37208
(P): 615-333-3939



Food and Beverage

Levy Restaurants, BCEC
415 Summer Street
Boston, MA 02210
(P): 617-954-2382
(E): exhibitorservices@signatureboston.com



Lead Retrieval

Convention Data Services (CDS)
107 Waterhouse Road
Bourne, MA 02532
(P): 508-759-8288



Photography

Oscar Einzig Photographers Inc.
566 W. Lake Street, Suite 430
Chicago, IL 60661
(P): 312-922-0056



Internet/Electric

Massachusetts Convention Center Authority
415 Summer Street
Boston, MA 02210
(P): 617-954-2230
(E): exhibitorservices@signatureboston.com



Floral

Stapleton Floral Design
200 Seaport Blvd- World Trade Center
Boston, MA 02210
(P): 617-399-9960



Booth Talent/Models

Convention Models/Talent Agency
(P): 866-238-9349
(E): cmtinfo@cmtagency.com

BOOTH DESIGN AND BUILD

Standard 10 foot Deep Linear Booth

Definition

One or more 10x10 units in a straight line.

Height

Exhibit fixtures, components and identification signs in the front 5' of the booth cannot exceed 4' in height. Exhibit displays and identification signs in the back 5' of the booth will be permitted to a maximum height of 8'.

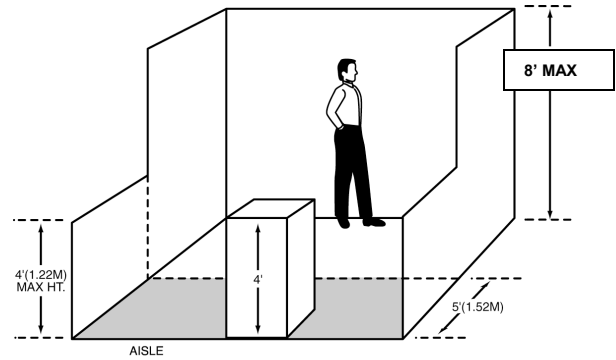

DISPLAY FIXTURES OVER 4' (1.22M) HIGH MUST BE CONFINED TO THAT AREA OF THE BOOTH THAT IS AT LEAST 5' (1.52M) FROM THE AISLE LINE

Intent

Each exhibitor is entitled to a reasonable sight line from the aisle. Exhibit spaces of 30 lineal feet or more, are able to use as much of the floor space as long as they do not interfere with the Rules and Regulations governing sight lines. Limiting display fixtures height and location is to accommodate the sight lines of neighboring exhibitors.

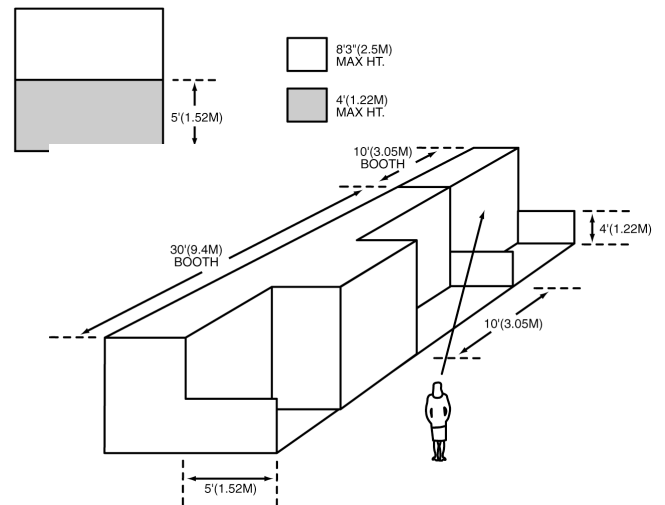

Hanging Signs

Hanging signs are not permitted in 10x10 booths.

If your exhibit has any variations from the Rules and Regulations, contact Show Management for written approval 60 days prior to set up.

Important

Space dimensions shown on floor plan are from the center line of the booth structure (side rails and back drape). Exhibit structures must be constructed to allow sufficient tolerance for utility service at rear of booth as well as building columns that may exist at the perimeter of the exhibit booth.

BOOTH DESIGN AND BUILD

Island Booth

Definition

An island booth is four or more 10x10 units, with a minimum side dimension of 20 feet, one or more display levels and aisles on all four sides.

Height

Exhibit fixtures, components and identification signs are permitted to a maximum height of 20'.

Multi Story Exhibits

All multi-story exhibits, regardless of whether people will occupy the upper area or not, and all exhibit fixtures and components exceeding 8' in height must have drawings submitted for approval.

Hanging Signs

A hanging sign is permitted over any island exhibit space 400 square feet or larger, provided it is not objectionable and there are no physical constraints within the facility. The maximum height of the top edge of the sign from the floor is twenty feet (20').

The following guidelines will apply to all exhibitors planning to hang a sign:

- Exhibitors must contact the Show Operations of Pri-Med to verify that a hanging sign is permissible over their contracted exhibit space.
- Shipping and installation arrangements for hanging signs are to be processed by the General Service Contractor. Please fill out and return the appropriate hanging sign order form.
- At the close of the show, hanging signs will be removed last. Exhibitors may need to make separate arrangements for shipping of these signs. Please check with the General Service Contractor for estimated removal time.

If your exhibit has any variations from the Rules and Regulations, contact Show Management for written approval 60 days prior to set up.

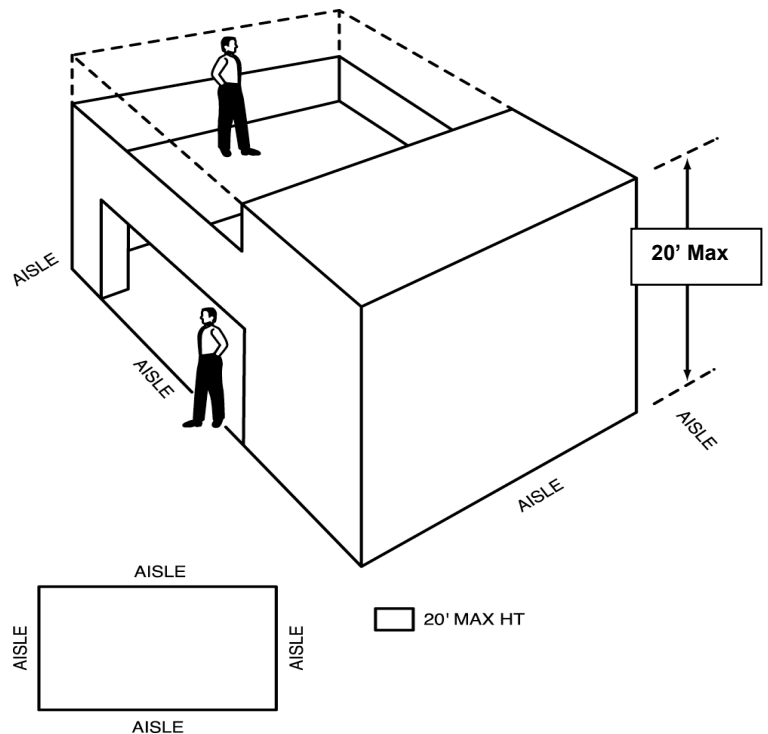

Important

Exhibitors are cautioned when installing a display with a ceiling or second level to check with the local fire department to insure that their display meets the necessary fire safety precautions involving smoke alarms, fire extinguishers, sprinkler systems, etc. Please note that the height of the ceilings alter depending on the convention center and your booth location. Check with the convention center and conference manager for the exact height above your booth.

BOOTH DESIGN AND BUILD

Perimeter Wall Booth

Definition

A perimeter booth is a 10x10 booth or larger located on the perimeter walls of the Exhibit Hall.

Height

Exhibit Fixtures, components and identification signs will be permitted to a maximum height of 12'. All display fixtures in the front 5' of the booth cannot exceed 4' in height.

Intent

Because the outer perimeter booths are not backed up against another exhibitor's booth, display back walls and materials over 8'0" will not interfere with or distract from any other exhibitor booth.

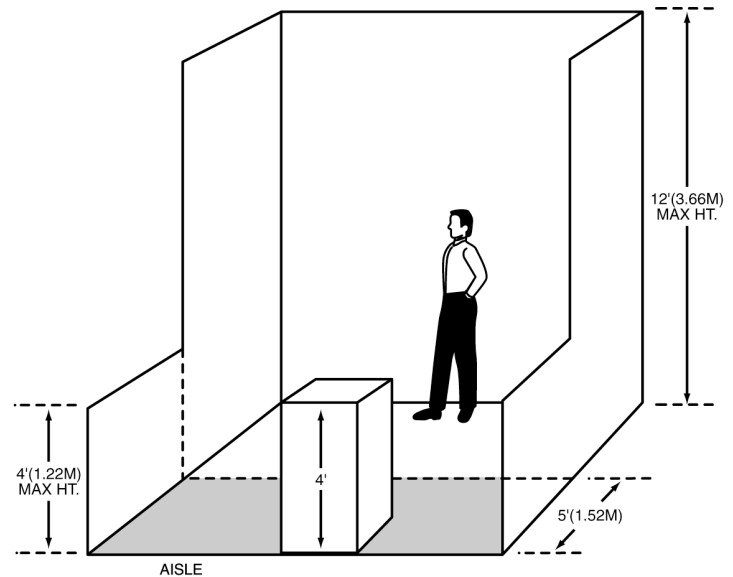

DISPLAY FIXTURES OVER 4' (1.22M) HIGH MUST BE CONFINED TO THAT AREA OF THE BOOTH THAT IS AT LEAST 5' (1.52M) FROM THE AISLE LINE

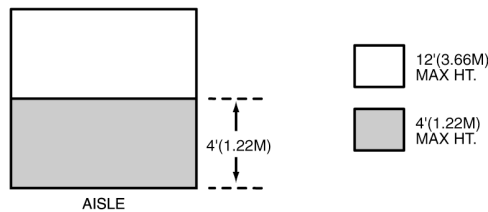

Important

Exhibitors are cautioned when installing a display with a ceiling or second level to check with the local fire department to insure that their display meets the necessary fire safety precautions involving smoke alarms, fire extinguishers, sprinkler systems, etc. Please note that the height of the ceilings alter depending on the convention center and your booth location. Check with the convention center and conference manager for the exact height above your booth.

If your exhibit has any variations from the Rules and Regulations, contact Show Management for written approval 60 days prior to set up.

Demonstrations

Definition

The part of the exhibit program involving the interaction of exhibit personnel and their audience through corporate presentations, product demonstrations or sampling.

Regulation

BOOTH DESIGN AND BUILD

Demonstration areas must be organized within the exhibitor's space so as not to interfere with any aisle traffic and sampling or demonstration tables must be placed a minimum of 2' from the aisle line.

Should spectators or samplers interfere with the normal traffic flow in the aisle or overflow into neighboring exhibits, exposition management will have no alternative but to request that the presentation or sampling be eliminated.

Intent

The aisles are the property of the entire show and each exhibitor has the responsibility to assure proper flow of traffic through the entire show. When large crowds gather to watch a demonstration or for sampling and interfere with the flow of traffic down aisles or create excessive crowds in neighboring booths, it is an infringement on the rights of other exhibitors. Aisles must not be obstructed at any time.

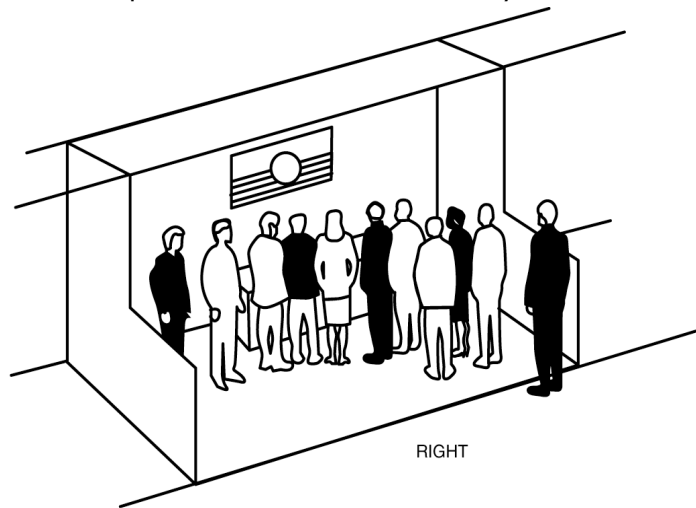

Sound

Exhibitors must police their own booths to be sure the noise levels from demonstrations or sound systems is kept to a minimum and does not interfere with others. Remember the use of sound systems or equipment producing sound is an exception to the rule, not a right. Exposition management reserves the right to determine at what point sound constitutes interference with others and must be discontinued.

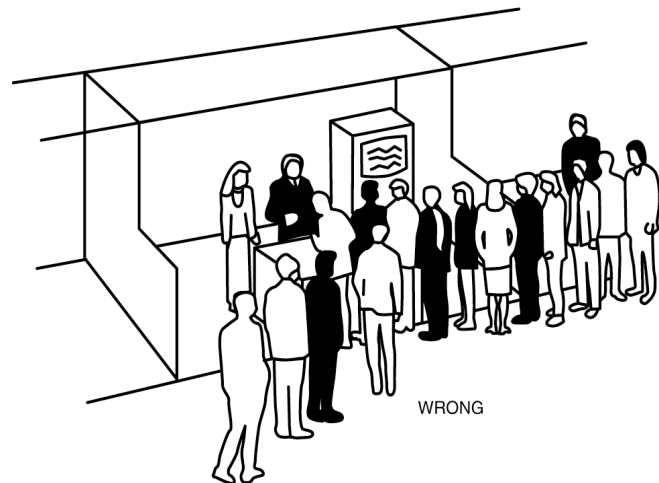

Safety Precautions

All product demonstrations involving any moving and potentially hazardous machines, displays or parts, must have hazard barriers to prevent accidental injury to spectators. Demonstrations must always be supervised by exhibitor personnel who can stop the demonstration in the event of an emergency and all demonstrations involving potentially hazardous by-products, such as dust, fumes, sparks or flames, must be approved in writing by exposition management 60 days prior to the show.

Please return form to:

Taylor Hill-Tout
Meetings Manager
Pri-Med
855 Boylston St. Suite 501
Boston, MA 02116
617-406-4295 (o)
thill-tout@pri-med.com

NAME OF SHOW: _____
COMPANY NAME _____ BOOTH #: _____
CONTACT NAME: _____ PHONE #: _____
E-MAIL ADDRESS _____

If your company plans to use a firm who is not an official service contractor as designated by Show Management, please complete this form and mail to the address listed above.

Company Name: _____ Booth No.: _____

Contact at Show: _____

Exhibitor Appointed Contractor: _____

Address: _____

Type of Service to be Performed: _____

Inform your **Exhibitor Appointed Contractor** that they **must** send a copy of their General Liability Insurance Certificate no later than 30 Days prior to the first day of exhibitor move-in or they will not be permitted to service your exhibit.

It is the responsibility of the exhibitor to see that each representative of an Exhibitor Appointed Contractor abides by the official rules and regulations of this event.

This form must be received 30 DAYS PRIOR TO THE FIRST DAY OF EXHIBITOR MOVE-IN.

NOTIFICATION OF INTENT TO USE EAC



EXCLUSIVE HOTEL & TRAVEL DISCOUNTS

You deserve the best rates and the best service. Pri-Med's official housing partner, onPeak, is a one-stop shop for all your hotel needs.



Reserve your room by November 16, 2021 to receive reduced rates at:

1. Aloft Boston Seaport District, a Marriott Hotel

401-403 D St

Single/Double Occupancy - \$205

2. Element Boston Seaport District, a Marriott Hotel

391-395 D St

Single/Double Occupancy - \$209

3. The Westin Boston Waterfront
425 Summer St

Single/Double Occupancy - \$229

Book your hotel through onPeak today:

www.pri-med.com/east (Click on the Hotels and Venue tab)

(800) 584 9017

primed@onpeak.com



Plan ahead. Reduced rates are available on a first-come, first-served basis. Rates do not include current tax.

Your Benefits



Deep Discounts



Hotel Reward Points



Best Rate Pledge

HEALTH AND SAFETY

Stay informed on Products, Services and Resources that will help you plan for a safe return to your next event. [Click Here](#) for our Health and Safety Resources.

BOOTH EQUIPMENT

Each 10' x 10' booth will be set with 8' high black back drape and 3' high black side drape. Booths 300 sqft or less will receive one 7" x 44" one-line identification sign. Booths larger than 300 sqft may receive an identification sign upon request.

EXHIBIT HALL CARPET

The exhibit area is not carpeted; however, aisles will be carpeted in tuxedo. Exhibitors are required to provide floor covering/carpet for their booth. Please refer to the enclosed Carpet Brochure and Order Form.

DISCOUNT PRICE DEADLINE DATE

Order early on [FreemanOnline](#) to take advantage of advance order discount rates, place your order by November 9, 2021.

EXHIBITOR FREQUENTLY ASKED QUESTIONS

For more information and helpful hints on products and services, ordering and invoicing, shipping your freight, and other top questions, please visit [FreemanOnline's FAQ page](#).

SHOW SCHEDULE

EXHIBITOR MOVE-IN

Tuesday	December 07, 2021	8:00 a.m. - 5:00 p.m.
Wednesday	December 08, 2021	8:00 a.m. - 5:00 p.m.

EXHIBIT HOURS

Thursday	December 09, 2021	8:30 a.m. - 4:15 p.m.
Friday	December 10, 2021	8:30 a.m. - 4:15 p.m.
Saturday	December 11, 2021	8:30 a.m. - 1:15 p.m.

EXHIBITOR MOVE-OUT

Saturday	December 11, 2021	1:15 p.m. - 8:00 p.m.
----------	-------------------	-----------------------

DISMANTLE AND MOVE-OUT INFORMATION

- All exhibitor materials must be removed from the exhibit facility by Saturday, December 11, 2021 at 8:00 p.m.
- To ensure all exhibitor materials are removed from the exhibit facility by the Exhibitor Move-Out deadline, please have all carriers check-in by Saturday, December 11, 2021 at 6:00 p.m.

EXHIBITOR SERVICE HOURS

Our Exhibitor Support team will be available from 8 a.m. - 5 p.m. from the first day of Exhibitor Move-in to the last day of Exhibitor Move-out. Hours may be extended the day before show open and the day of show close to assist with additional exhibitor needs.

POST SHOW PAPERWORK AND LABELS

Exhibitor Support will gladly prepare your outbound Material Handling Agreement and labels in advance. Complete the Outbound Shipping form and your paperwork will be available at show site. Be sure your carrier knows the company name and booth number when making arrangements for shipping your exhibit at the close of the show.

EXCESSIVE TRASH AND BOOTH ABANDONMENT

Any excessive trash which consists of display materials, carpet, padding, crates and/or pallets will be disposed of and charged both a handling fee and disposal fee during exhibitor move-in. Excessive booth materials and/or literature left in the booth at the end of the published exhibitor move-out that is not labeled for an outbound shipment will be considered abandoned and deemed as trash. The exhibitor will be charged for the removal and disposal of these items. Charges may include Installation & Dismantle Labor, Forklift & Rigging Labor, and/or Dumpster Fee. Please call Exhibitor Support at (888) 508-5054 for an estimate.

SERVICE CONTRACTOR CONTACTS / INFORMATION:

FREEMAN

(888) 508-5054 Fax (469) 621-5608

ExhibitorSupport@freeman.com

FREEMAN EXHIBIT TRANSPORTATION

(800) 995-3579 US & Canada or +1(512) 982-4187 Outside the US or +1(817) 607-5183

International Shipping Services or fax (469) 621-5810 or Exhibit.Transportation@freeman.com

FREEMAN ONLINE®

Take advantage of discount pricing by ordering online at [FreemanOnline](#) by November 9, 2021. Using the enhanced FreemanOnline, you will enjoy easy access to added features and functions as well as the high caliber of Freeman services you've come to expect — **before, during and after** your show.

To place online orders, you will be required to enter your unique Username and Password. If this is your first time to use FreemanOnline, click on the "Create an Account" link. To access Freeman Online without using the email link, visit [FreemanOnline](#).

If you need assistance with Freeman Online, please call Exhibitor Support at (888) 508-5054 Toll Free US and Canada or +1(512) 982-4186 Local and International.

SHIPPING INFORMATION

Warehouse Shipping Address:

Exhibiting Company Name / Booth #

DBC PRI-MED EAST

C/O TFORCE FREIGHT / FREEMAN

80 CONCORD ST

NORTH READING, MA 01864

Freeman will accept crated, boxed or skidded material beginning Monday, November 8, 2021 at the above address. Material arriving after November 30, 2021 will be received at the warehouse with an additional after deadline charge. Please note that the Freeman Warehouse does not accept uncrated freight (loose, pad-wrapped material and/or unskidded machinery), COD shipments, hazardous materials, freight requiring refrigerated or frozen storage, a single piece of freight weighing more than 5,000 pounds or a single piece of freight beyond the dimensions of 108" H x 93" W. Warehouse materials are accepted at the warehouse Monday through Friday between the hours of 8:00 AM - 4:30 PM. Certified weight tickets must accompany all shipments. If required, provide your carrier with this phone number: (888) 508-5054.

Show Site Shipping Address:

Exhibiting Company Name / Booth #

DBC PRI-MED EAST

BOSTON CONVENTION & EXHIBITION CENTER

C/O FREEMAN

415 SUMMER ST

BOSTON, MA 02210

Freeman will receive shipments at the exhibit facility beginning Tuesday, December 7, 2021. Shipments arriving before this date may be refused by the facility. Any charges incurred for early freight accepted by the facility will be the responsibility of the exhibitor. Certified weight tickets must accompany all shipments. If required, provide your

Please note: Any materials received by Freeman are subject to Material Handling Charges and are the responsibility of the Exhibitor. This also applies to items not ordered through the Official Show Vendors. Refer to the material handling form for charges for the service.

Please be aware that disposal of exhibit properties is not included as part of your material handling charges. Please contact Freeman for your quoted rates and rules applicable to disposal of your exhibit properties.

PURCHASE TERMS

Freeman's Terms & Conditions apply to all orders submitted to Freeman for any goods or services, and may be amended without notice. To review the current Terms & Conditions, [click here](#).

LABOR INFORMATION

Union Labor may be required for your exhibit installation and dismantle. Please carefully read the UNION RULES AND REGULATIONS to determine your needs. Exhibitors supervising Freeman labor will need to pick up and release their labor at the Labor Desk. Refer to the order form under Display Labor for Straight time and Overtime hours.

ASSISTANCE

We want you to have a successful show. If we can be of assistance, please call Exhibitor Support at (888) 508-5054.

WE APPRECIATE YOUR BUSINESS!

FREEMAN GENERAL INFORMATION

TRANSLATION SERVICE

Freeman is pleased to offer a new service for our international exhibitors that provides quick interpretation and translation in 150 languages. This service will not only interpret for us on a three-way conversation, but also translate emails from customers. To access this service you may contact Exhibitor Support at (888) 508-5054 US & Canada or +1(512) 982-4186 Local & International.

HELPFUL HINTS

SAVE MONEY

Order early on [FreemanOnline](#) to take advantage of advance order discount rates, place your order by November 9, 2021.

AVOID DELAY

Ship early to avoid delays. Shipments arriving late at show site will cost you money, time and business!

SAFETY TIPS

Use a ladder, not a chair. Standing on chairs, tables and other rental furniture is unsafe and can cause injury to you or to others. These objects are not designed to support your standing weight.

Be aware of your surroundings. You are in an active work area with changing conditions during move-in and move-out. Pay attention. Look for obstacles, and machinery and equipment that are in use.

Keep your eyes open for scooters and forklifts. The drivers of these vehicles may not be able to see you.

Stay clear of dock areas, trucks and trailers. These areas can be particularly dangerous.

Prevent electrical shocks, falling items and damage to materials. Do not attach items or equipment to the drapes or metal framework provided for you booth. This can cause serious injury or damage to materials.

We discourage children from being in the exhibit hall during installation and dismantle. If children are present during installation and dismantle, they must be supervised by an adult at all times.

Freeman does not ship or handle Hazardous Materials. If any materials you are shipping to the event fall into this category, please contact Freeman to be sure that the material will be allowed at the facility and by the association. In addition, if authorized by the facility and the association, you will need to make separate arrangements for the transport and handling of the approved materials, since Freeman will not transport or handle them.

The operation or use of all motorized lifts and motorized material handling equipment for installation/dismantle of exhibits is NOT permitted by exhibitors or by their exhibitor appointed contractors (EACs). Thank you for your cooperation

Call Exhibitor Support at (888) 508-5054 with any questions or needs you may have.

Interested in going green and saving money?

Follow these tips to make sure your sustainable booth strategies are cost-neutral or even cost-saving! Leave an impact on the show floor, not the environment.



1 BEFORE THE SHOW

booth structure

Option 1 Multiple Use

Use **Forest Sustainable Certified (FSC)** wood to build your booth and crates.

Get creative! Design your booth with a **small shipping footprint** to minimize carbon emissions. Freeman's eye-catching stretch-fabric booth designs pack up small (and light!) for shipping.

Option 2 One-time Use

Rent locally from nearby Freeman offices to reduce both shipping costs and carbon emissions.

2 carpet

Option 1 Rent

Rent rather than buy carpet to save on shipping, cleaning, and storage. Freeman Classic carpet can be reused at least four times.

Option 2 Color

Use darker-colored carpet, which is easier to reuse and recycle. Freeman Classic dark-colored carpets are made of 20-50 percent recycled content.



3 shipping

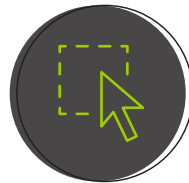

Online + before deadline = better bottom line. Take advantage of early-bird pricing and consolidate shipping when ordering supplies.

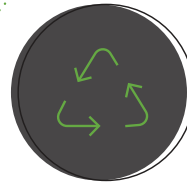

Choose reusable shipping padding. Avoid packing peanuts and foam plastic materials that never decompose.



Ship early. Use the 30-day policy to ship materials to the Freeman advance warehouse.

4 graphics

Option 1 Multiple Use

Print on a durable substrate **without dates, event names, or locations.**

Option 2 One-time Use

Print on 100 percent recyclable materials like Freeman Honeycomb and Smartbuild Eco, which are just as cost-effective as PVC.

5 printing



Reduce printing and **go digital** with your booth literature.



Print locally. Supporting local businesses while reducing shipping? It's a win-win.



Print on at least **50 percent post-consumer recycled paper.**

6

ON SITE

save energy



Use Energy Star-rated equipment for audio-visual equipment and monitors.



Power down. Turn off equipment at the end of each day.



Light up your booth with CFLs, LEDs, or other energy-efficient lighting.

8

shipping out

Pack in, pack out.

Leave no traces on show site.

Join a caravan.

If you're shipping directly to another show, ask **Freeman Transportation about joining a caravan** to your next show.

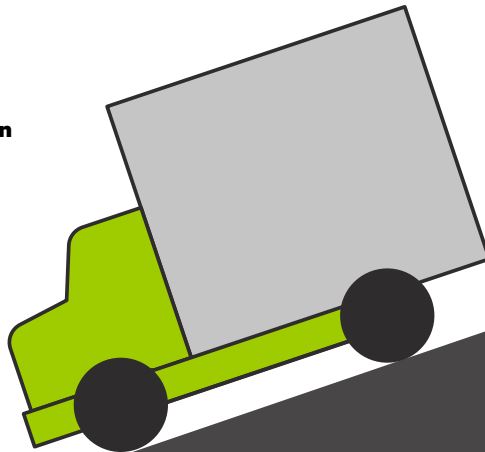

9

leftover materials

Remember to label.

Clearly **label recyclable leftover material** for disposal.

Donate the rest.

Ask the Freeman Exhibitors Services desk about local donation programs.

7

MOVE OUT

train your team

Educate your installation and dismantling teams about **recycling and donation processes.**

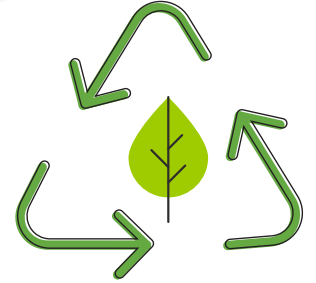

TYPICALLY* DONATE-ABLE

Furniture: Purchased items
Home furnishing: Décor staging materials

Unused raw materials: Plywood, subflooring, non-laminate wood

Flooring: 100 square feet of flooring. Excludes carpet.

Left over giveaways: Pens, pads of paper, sunglasses, USBs, etc., left over in your promotional giveaway

TYPICALLY* RECYCLABLE

Cardboard: Used for signs or shipping boxes

Glass: Green, brown, clear

Plastics: Shrink-wrap or plastic banding used to secure shipments; water/soda bottles; plexiglass (acrylics) clear, smoked, or tinted; Visqueen used to protect flooring

Metal: Aluminum cans/ steel banding

Paper: Fliers, brochures, programs, tickets, office paper, newspaper, magazines, paperboard

Wood: Non-laminate wood

The storage of combustible shipping containers must be confined to areas approved by the Fire Marshal.

The use, display, or storage of LPG, flammable liquid, or flammable gas must be approved by the Fire Marshal in writing.

The use of open flames, burning, or smoke-emitting materials as part of an act, display, or show is prohibited.

Combustible waste is to be collected as it accumulates and shall be stored in non-combustible, covered containers which are emptied at least once a day.

The use of welding and cutting equipment for demonstration purposes must be by permit from the Fire Marshal.

The use of compressed gas cylinders must be approved by the Fire Marshal and cylinders must be firmly secured in an upright position.

All commercial type cooking appliances shall be equipped with ventilation hoods and approved automatic extinguishing systems. All other cooking devices shall have adequate separation from combustible materials by spacing or non-combustible shielding.

The use of any gas-fired appliance must be approved by the Fire Marshal; the use of salamander stoves is prohibited.

Sawdust and shavings shall be kept flame-proofed.

The storage of hay and straw must be approved by the Fire Marshal.

Electrical equipment must be installed, operated, and maintained in a manner which does not create a hazard to life or property.

Provide for daily removal of trash and rubbish.

No curtains, drapes or decorations shall be hung in such a manner as to cover any exit signs.

No vehicles shall be parked in fire lanes outside of buildings.

Artificial lighting such as lanterns and candles are prohibited.

All flammable liquids used in any exhibit area shall be stored in an Underwriter's Laboratories labeled safety can.

BASIC RULES

Automotive vehicles and equipment may be displayed if:

- a. There is not more than 3 gallons of fuel or the minimum amount for positioning.
- b. Fuel tanks are locked or sealed.
- c. The battery cable used to start the engine must be disconnected and the end of the disconnected battery cable taped
- d. Ignition keys are removed and at display location.
- e. No vehicle may be operated on exhibit hall without a lead person walking in front of the vehicle warning people of vehicle movement

FLAME RETARDANT TREATMENT

All decorations, drapes, signs, banners, acoustical materials, hay, straw, moss, split bamboo, plastic cloth and similar decorative materials, shall be flame retarded to the satisfaction of the Boston Fire Department and State Fire Marshal.

Combustible materials 3/8" or more in thickness, glass or asbestos cloth may be used without flame retardant treatment.

The use of oilcloth, tarpaper, sisal paper, nylon, Orlon and certain other plastic materials which cannot be flame retardant is prohibited.

Table coverings must be flame retardant treated unless they lie flat, with an overhang of no greater than 6".

All materials must be certified by the Boston Fire Department within (6) months of the event. The Boston Fire Department does not accept certificates from other jurisdictions. Materials may be sent directly to the Boston Fire Department for testing.

The City of Boston Fire Code prohibits the use of:

- fabric attached to a ceiling or used to cover any portion of an exhibit.
- carpet on ceilings, walls, seating products, or as decorative material.

PERMITS

Fire Department - Application for a permit for the following shall be made five days in advance of the show:

1. Display and operate any heater, barbecue, heat producing device, open flames, candles, lamps, lanterns, torches, etc.
2. Display or operate any electrical mechanical or chemical device which may be deemed hazardous by the Fire Department.
3. Use or store flammable liquids, compressed gasses or dangerous chemicals.
4. Any autos, trucks, motorcycles or other motorized vehicles displayed shall have their batteries removed (or battery cables removed) and their fuel supplies reduced to not more than (3) gallons. All motor vehicle tanks containing fuel, or which have ever contained fuel, shall be furnished with locking type caps or sealed with tape to preclude "viewers" inspection. Garden tractors, chain saws, power plants, and other gasoline powered equipment shall be safeguarded in a similar manner.

COMBUSTIBLES

Literature on display shall be limited to reasonable quantities. Reserve supplies shall be kept in closed containers and stored in a neat and compact manner.

OBSTRUCTIONS

Aisles and exits as designated on approved show plans shall be kept clean, clear and free of obstructions. Booth constructions shall be substantial and fixed in position in specified areas for the duration of the show. Easels, signs, etc., shall not be placed beyond booth area into aisles.

Fire fighting equipment shall be provided and maintained in accessible, easily seen locations.

PORTABLE SPOTLIGHTS

Only clamp-on types of portable spotlights are allowed, with porcelain base and metal guards.

Use of ceramic-porcelain or molded composition type of neck-shell is the only type approved for use in a Boston Convention Facility. On/off switches are usually located in the neck.

Where any spotlight or lamp is subject to physical damage, damp places, or comes into contact with combustible material, it shall be equipped with a substantial guard attached to the lamp holder or the handle.

Flexible cord extensions may only be used for portable lamps/appliances that are of allowable amperage for the size and type of a three (3) conductor cord connected to and for the utilization of any equipment. The third conductor is used for equipment grounding purposes.

THESE ARE BASIC RULES AND EVERY EXHIBIT MUST COMPLY PRIOR TO SCHEDULED OPENING. FOR ASSISTANCE PLEASE CONTACT THE BOSTON FIRE DEPARTMENT. - Fire Marshal

PAYMENT INFORMATION

Freeman only accepts payment information electronically. Place your order on [FreemanOnline](#) or follow the steps below to provide your payment information electronically and submit your order forms.

Freeman will no longer accept cash payments for any Freeman services.

1. Submit your payment information

Proceed to our electronic Freeman Pay site to securely submit your payment information

<https://www.freemanpay.com/482955>

2. Submit your order

Upload your order forms through the same link used to submit your payment information

- **Both your order and your payment must be received by the discount price deadline date to guarantee discount pricing.**
- **Orders received without payment or after the discount price deadline date will be charged at the standard price.**
- **Copies of invoices may be picked up from the Freeman Service Center prior to show closing.**

before event

during the event

after event

from your location
or previous event

to your location
or next event

event venue

venue
dock

your exhibit

venue
dock

advance
warehouse

storage for empty containers



advance warehouse

where exhibit materials are
stored before an event



shipping

transport to the venue's shipping
dock then from the shipping dock to
the next event or customer location



material handling

move items from the dock, to the
exhibit, back to the dock after the show

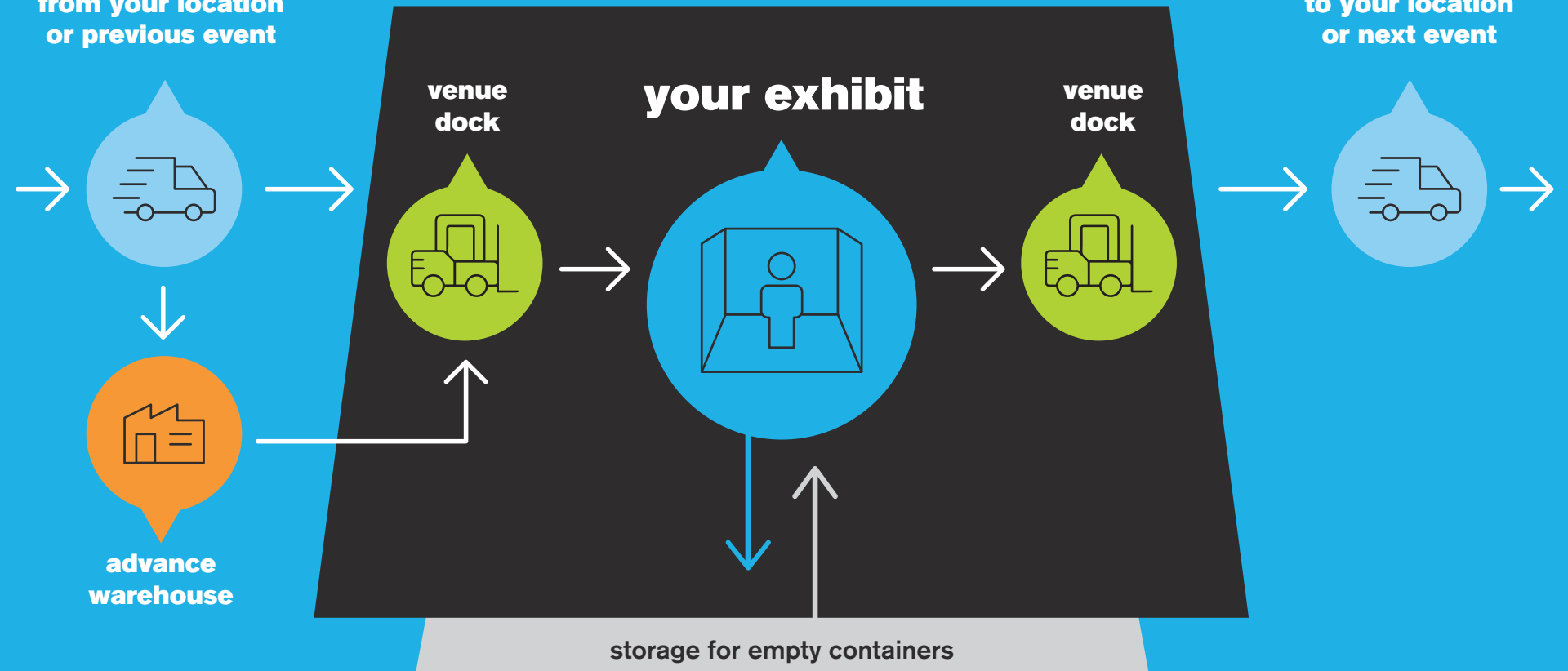

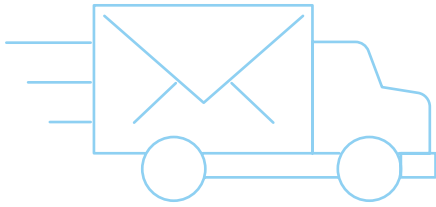

TRANSPORTATION SERVICE, FULLY LOADED.

Our convenient, affordable package puts productivity in overdrive.

Turn to Freeman for one-stop transportation services. Our all-inclusive round trip standard ground shipping and material handling package means transporting materials to any exhibit location has never been easier or more affordable. Plus, Freeman works directly with you and show site decision makers to streamline the process, so it's faster than ever to get on the road to success.

The Freeman Exhibit Transportation promise:

- ALL-INCLUSIVE PRICING WITH NO ADDITIONAL FEES FOR PICKUPS AND DELIVERIES, INCLUDING WEEKEND AND NIGHT SERVICE
- PICK-UP AND TRANSPORTATION FROM POINT OF ORIGIN TO YOUR CHOICE OF EITHER ADVANCE WAREHOUSE OR SHOW SITE
- ON-SITE TRANSPORTATION EXPERTS ARE AVAILABLE BEFORE, DURING AND AFTER THE SHOW
- RELIABLE CUSTOMER SERVICE SEVEN DAYS A WEEK, OFFERING COMPLETE SHIPMENT VISIBILITY AND EXPERT SUPERVISION
- PRE-PRINTED SHIPPING LABELS AND OUTBOUND PAPERWORK

Benefits:

- TURNKEY PRICING ENSURES PRECISE BUDGETING
- NO ADDITIONAL HANDLING, PICK-UP OR DELIVERY FEES
- NO ADDITIONAL FUEL SURCHARGES OR OVERTIME SURCHARGES
- NO CARRIER WAITING TIME FEES
- EXPERIENCED ON-SITE TRANSPORTATION REPS FROM MOVE-IN THROUGH MOVE-OUT
- LTL (LESS THAN TRUCK LOAD) SHIPPING

*Services apply to destinations anywhere in the Continental U.S.



To take advantage, call **1-800-995-3579** or email **exhibit.transportation@freeman.com** for a quote.

RESULTS, DELIVERED

With more than 90 years of experience in the events industry, no one understands exhibit transportation better than Freeman. Our transportation services are a seamless extension of the premium products that exhibitors around the world rely on time and time again.

Between our all-inclusive pricing and superior customer service, Freeman Exhibit Transportation is the most reliable, convenient and cost-effective solution available. Our team of experts has the ability to quickly respond to changes when necessary, remaining entirely responsive to all of your show requirements, whenever and wherever they arise.

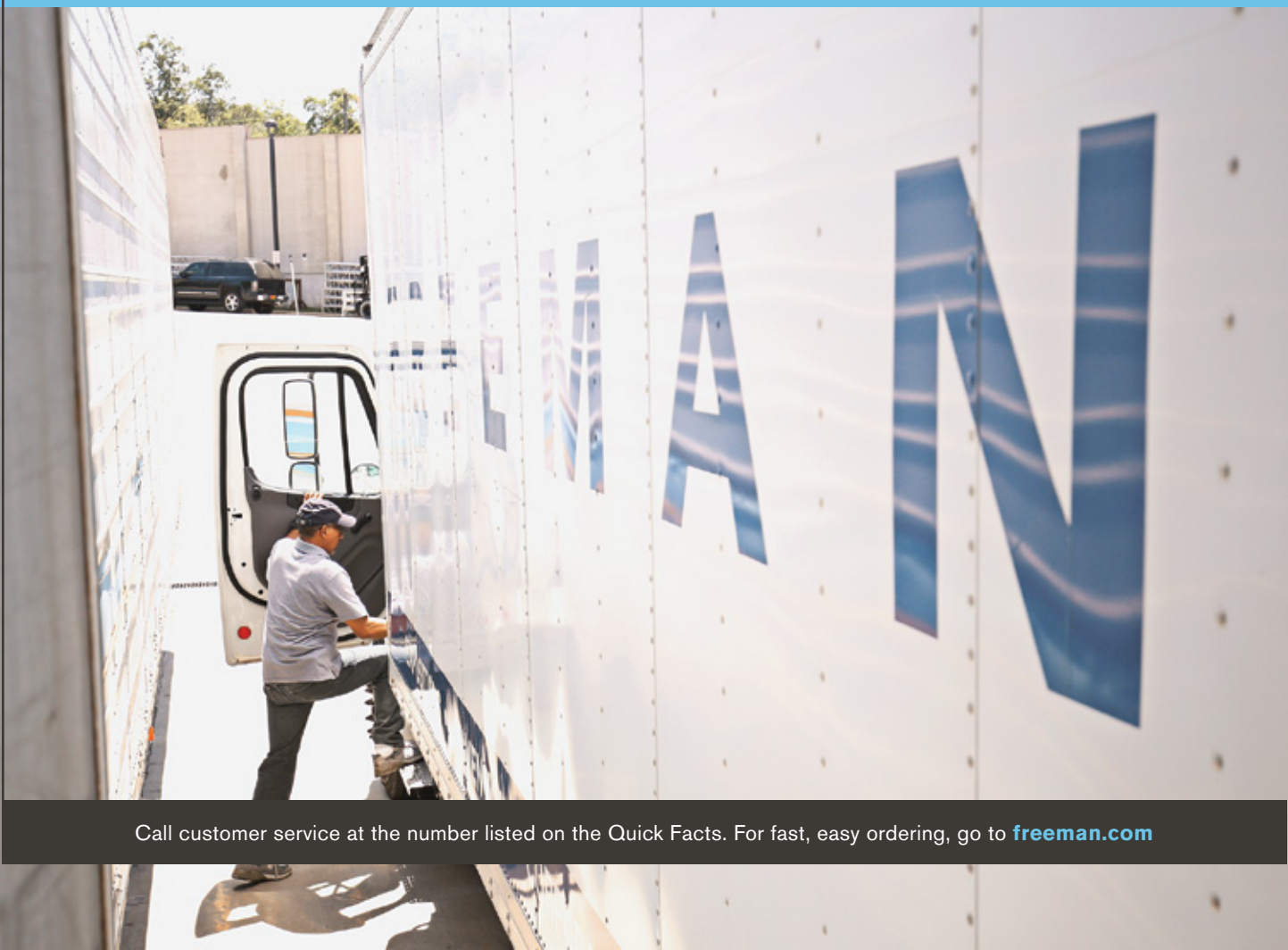

Call customer service at the number listed on the Quick Facts. For fast, easy ordering, go to freeman.com

EXHIBIT TRANSPORTATION SERVICES

Freeman Exhibit Transportation is an EPA Smartway Partner and is dedicated to reducing carbon emissions related to the transportation of goods. Renting or shipping items locally saves on carbon emissions and your shipping footprint.

Freeman Exhibit Transportation promise:

- ALL-INCLUSIVE PRICING WITH NO ADDITIONAL FEES FOR PICKUPS AND DELIVERIES, INCLUDING WEEKEND AND NIGHT SERVICE
- ONE CONVENIENT INVOICE ENCOMPASSING ALL FREEMAN SHOW SERVICES
- ON-SITE TRANSPORTATION EXPERTS ARE AVAILABLE BEFORE, DURING AND AFTER THE SHOW
- RELIABLE CUSTOMER SERVICE SEVEN DAYS A WEEK, OFFERING COMPLETE SHIPMENT VISIBILITY AND EXPERT SUPERVISION

Questions?

For more information regarding our services, rates, shipment deadlines, documentation requirements, ordering and the terms and conditions of our service offerings, please visit freeman.com

Continental U.S. Exhibitors: Contact our exhibit transportation experts at **800.995.3579** or via email at exhibit.transportation@freeman.com

International Exhibitors: Contact our exhibit transportation experts at **+1.817.607.5183** or via email at international.freight@freeman.com

DON'T FORGET ABOUT INBOUND SHIPPING! COMPLETE AND SEND THE ORDER FORM

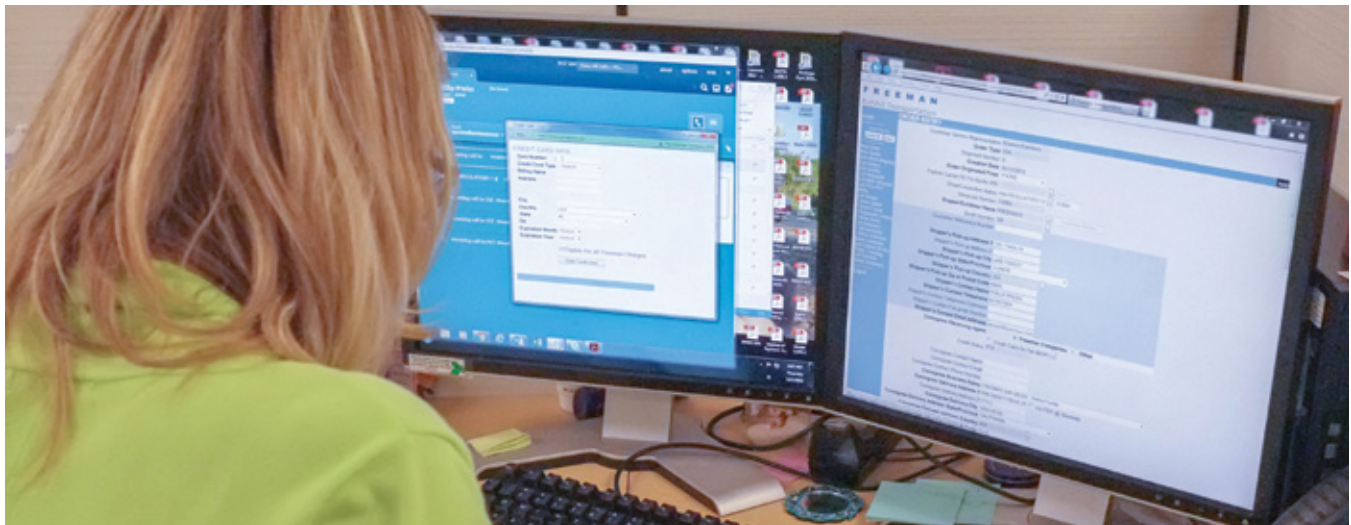

FREEMAN

(800) 995-3579 Toll Free US & Canada
(817) 607-5183 Local & International

COMPLETE THIS FORM ONLY IF YOU ARE
SHIPPING YOUR EXHIBIT MATERIALS BY
FREEMAN EXHIBIT TRANSPORTATION

exhibit transportation

NAME OF SHOW: **DBC PRI-MED EAST / DECEMBER 9 - 11, 2021**

COMPANY NAME: _____ BOOTH #: _____

CONTACT NAME : _____ PHONE #: _____

E-MAIL ADDRESS : _____

For fast, easy ordering, go to www.freeman.com/store.

EXHIBIT TRANSPORTATION

TIPS FOR EASY ORDERING

- Credit card information must be on file prior to pick up, as charges will be included on your show services invoice.
- International Exhibitors remember - Shipments originating from countries other than the US must be cleared through customs. Please call for additional information:
(800) 995-3579 Toll Free US & Canada
(817) 607-5183 Local & International

COMPLETE THE FOLLOWING ITEMS ON THIS FORM:

PICK UP INFORMATION

Requested Pick Up Date: _____

SHIPPER NAME _____

SHIPPER ADDRESS _____

(City) (State) (Zip Code)

DESTINATION

- I will be shipping to the **WAREHOUSE**

FREEMAN / Exhibiting Company Name / Booth #

DBC PRI-MED EAST

C/O: TFORCE FREIGHT / FREEMAN

80 CONCORD ST

NORTH READING, MA 01864

MUST BE DELIVERED BY NOVEMBER 30, 2021

- I will be shipping to **SHOW SITE**

FREEMAN / Exhibiting Company Name / Booth #

DBC PRI-MED EAST

C/O: FREEMAN

BOSTON CONVENTION & EXHIBITION CENTER

415 SUMMER ST

BOSTON, MA 02210

CANNOT BE DELIVERED BEFORE DECEMBER 07, 2021

TYPE OF SERVICE

- Next Day Air: Delivery next business day by 5:00 PM
- Second Day Air: Delivery second business day by 5:00 PM
- 3-5 Day Service: Delivery within 3 - 5 business days
- Declared Value \$ _____

Air Transportation charges are billed by Dimensional or Actual Weight, whichever is greater.

- Standard Ground: Dependent on distance
- Expedited Ground: Tailored to specific requirements
- Specialized: Pad wrapped, uncrated, truck load

01/21

SHIPPING INFORMATION

Items to be shipped

Number of Pieces	Est. Weight
____ Crates (wooden)	_____
____ Cartons (cardboard)	_____
____ Cases/Trunks (fiber) (color _____)	_____
____ Skids/Pallets	_____
____ Carpet (color _____)	_____
____ Other (_____)	_____
____ Total	_____

Size of largest piece: (H) _____ (W) _____ (L) _____

NOTE: Shipments will be weighed and measured prior to delivery.

OUTBOUND SHIPPING

- I would like to schedule outbound Freeman Exhibit Transportation. Please provide me with a Material Handling Agreement at show site for my shipping instructions and signature. So we may print your Outbound Material Handling Agreement and labels, please complete the following information **if different from pick up address:**

Ship to address:

Number of Labels : _____

FAX THIS COMPLETED FORM VIA:

E-mail:

exhibit.transportation@freeman.com

or

Fax: (469) 621-5810

**A TRANSPORTATION SPECIALIST
WILL CALL YOU TO CONFIRM
RECEIPT OF SHIPMENT REQUEST
AND FINALIZE DETAILS.**

SHOW # (482955) _____

WHAT ARE FREIGHT SERVICES?

As the official service contractor, Freeman is the exclusive provider of freight services. Material handling includes unloading your exhibit material, storing up to 30 days in advance at the warehouse address, delivering to the booth, the handling of empty containers to and from storage, and removing of material from the booth for reloading onto outbound carriers. It should not be confused with the cost to transport your exhibit material to and from the convention or event. You have two options for shipping your advance freight — either to the warehouse or directly to show site.

HOW DO I SHIP TO THE WAREHOUSE?

- We will accept freight beginning 30 days prior to show move-in.
- To check on your freight arrival, call Exhibitor Services at the location listed on the Quick Facts.
- To ensure timely arrival of your materials at show site, freight should arrive by the deadline date listed on the Quick Facts. Your freight will still be received after the deadline date, but additional charges will be incurred.
- The warehouse will receive shipments Monday through Friday, except holidays. Refer to the Quick Facts for warehouse hours. No appointment is necessary.
- The warehouse will accept crates, cartons, skids, trunks/cases and carpets/pads. Loose or pad-wrapped material must be sent directly to show site.
- All shipments must have a bill of lading or delivery slip indicating the number of pieces, type of merchandise and weight.
- Shipments received without receipts or freight bills, such as Federal Express and UPS, will be delivered to the booth without guarantee of piece count or condition.
- Certified weight tickets must accompany all shipments.
- Warehouse freight will be delivered to the booth prior to exhibitor set up.

HOW DO I SHIP TO SHOW SITE?

- Freight will be accepted only during exhibitor move-in. Please refer to the Quick Facts for the specific exhibitor move-in dates and times.
- All shipments must have a bill of lading or delivery slip indicating the number of pieces, type of merchandise and weight.
- Shipments received without receipts or freight bills, such as Federal Express and UPS, will be delivered to the booth without guarantee of piece count or condition.
- Certified weight tickets must accompany all shipments.

WHAT ABOUT PREPAID OR COLLECT SHIPPING CHARGES?

- Collect shipments will be returned to the delivery carrier.
- To ensure that your freight does not arrive collect, mark your bill of lading “prepaid.”
- “Prepaid” designates that the transportation charges will be paid by the exhibitor or a third party.

HOW SHOULD I LABEL MY FREIGHT?

- The label should contain the exhibiting company name, the booth number and the name of the event.
- The specific shipping address for either the warehouse or show site is located on the Quick Facts.

HOW DO I ESTIMATE MY MATERIAL HANDLING CHARGES?

- Charges will be based on the weight of your shipment. Each shipment received is billed individually. All shipments are subject to reweigh.
- On the Material Handling Form, locate the rate that applies to your shipment and multiply that rate by the weight of your shipment in pounds.
- The above services, whether used completely or in part, are offered as a package and the charges will be based on the total inbound weight of the shipment.

WHAT HAPPENS TO MY EMPTY CONTAINERS DURING THE SHOW?

- Pick up “Empty Labels” at the Freeman Service Center. Once the container is completely empty, place a label on each container individually. Labeled empty containers will be picked up periodically and stored in non-accessible storage during the event.
- At the close of the show, the empty containers will be returned to the booth in random order. Depending on the size of the show, this process may take several hours.

HOW DO I PROTECT MY MATERIALS AFTER THEY ARE DELIVERED TO THE SHOW OR BEFORE THEY ARE PICKED UP AFTER THE SHOW?

- Consistent with trade show industry practices, there may be a lapse of time between the delivery of your shipment(s) to your booth and your arrival. The same is true for the outbound phase of the show — the time between your departure and the actual pick-up of your materials. During these times, your materials will be left unattended. We recommend that you arrange for a representative to stay with your materials or that you hire security services to safeguard your materials.

HOW DO I SHIP MY MATERIALS AFTER THE CLOSE OF THE SHOW?

- Each shipment must have a completed Material Handling Agreement in order to ship materials from the show. All pieces must be labeled individually.
- To save time, complete and submit the Outbound Shipping Form in advance, or you may contact the Freeman Service Center at show site for your shipping documents.
- Once we receive your outbound shipping information we will create your Material Handling Agreement and shipping labels. If the shipping information is provided in advance, the Material Handling Agreement will be delivered to your booth with your invoice. Otherwise the Material Handling Agreement and labels will be available for pick up at the Freeman Service Center.
- After materials are packed, labeled, and ready to be shipped, the completed Material Handling Agreement must be turned in at the Freeman Service Center.
- Call your designated carrier with pick-up information. Please refer to the Quick Facts for specific dates, times and address for pick up. In the event your selected carrier fails to show by the final move-out day, your shipment will either be rerouted on Freeman's carrier choice or delivered back to the warehouse at the exhibitor's expense.
- For your convenience, approved show carriers will be on site to book outbound transportation if you have not made arrangements in advance.

WHERE DO I GET A FORKLIFT?

- Forklift orders to install or dismantle your booth after materials are delivered may be ordered in advance or at show site. We recommend that you order in advance to avoid additional charges at show site. Refer to the Rigging Order Form for available equipment.
- Advance and show site orders for equipment and labor will be dispatched once a company representative signs the labor order at the Freeman Service Center.
- Start time is guaranteed only when equipment is requested for the start of the working day.

DO I NEED INSURANCE?

- Be sure your materials are insured from the time they leave your firm until they are returned after the show. It is suggested that exhibitors arrange all-risk coverage. This can be done by riders to your existing policies.
- All materials handled by Freeman are subject to the Terms and Conditions, which can be found in the exhibit service manual or online at www.freeman.com.

OTHER AVAILABLE FREIGHT SERVICES

(may not be available in all locations)

- Cranes
- Accessible storage at show site
- Exhibit transportation services (see enclosed brochure)
- Security storage at show site
- Short-term and long-term warehouse storage
- Local pick-up and delivery
- Priority empty return

FREEMAN®

material handling simplified

Our new straight forward pricing makes pre-show budgeting easier. Pay for your actual weight per-pound with no invoice surprises.

- × No minimums
- × No crated
- × No special handling
- × No carpet & pad only
- × No uncrated
- × No hundred-weight billing
- × No reweigh fees
- × No overtime
- × No marshalling yard fees
- × No rounding - pay only for actual weight

It's just easier!



MATERIAL HANDLING

Freeman is the exclusive provider of material handling services. Material handling includes unloading your exhibit material, storing up to 30 days in advance at the warehouse address, delivering to the booth, the handling of empty containers to and from storage, and removing of material from the booth for reloading onto outbound carriers. You have two options for shipping your advance freight - either to the warehouse or directly to show site. Material handling charges will automatically be applied to your account upon receipt of each shipment. It is not necessary to return this form to receive material handling services.

RATES

Material Handling	\$	2.00 per pound
Rate applies to shipments sent to either the warehouse or directly to show site.		
Material Handling - After Deadline	\$	2.50 per pound
Rate applies to shipments arriving at the warehouse after NOVEMBER 30, 2021 .		
Material Handling - 10 lbs and under		Free of Charge
This rate is per shipment. A qualifying shipment totals any number of pieces delivered to the same booth, by the same carrier, from the same shipper, on the same day, weighing 10 pounds or less.		

IMPORTANT SHIPPING INFORMATION

Freeman Exhibit Transportation offers fast and easy service! Please call (800) 995-3579 to have one of our representatives help arrange all your shipment needs.

Warehouse:

- Avoid wait times at show site; ship to our warehouse!
- Warehouse receiving begins on **NOVEMBER 8, 2021**.
- Warehouse address: **Exhibiting Company Name / Booth #
DBC PRI-MED EAST
C/O TForce Freight / Freeman
80 Concord St
North Reading, MA 01864**
- Please note that the Freeman warehouse does not accept uncrated freight (loose, pad-wrapped material and/or unskidded machinery), COD shipments, hazardous materials, freight requiring refrigeration or frozen storage, a single piece of freight weighing more than 5,000 pounds or a single piece of freight beyond the dimensions of 108"H x 93"W.

Show Site:

- Show site receiving begins on **DECEMBER 7, 2021**.
- Show Site address: **Exhibiting Company Name / Booth #
DBC PRI-MED EAST
Boston Convention & Exhibition Center
C/O Freeman
415 Summer St
Boston, MA 02210**

Outbound:

- Submit your outbound shipping information in advance and we will deliver your paperwork to your booth during the show.

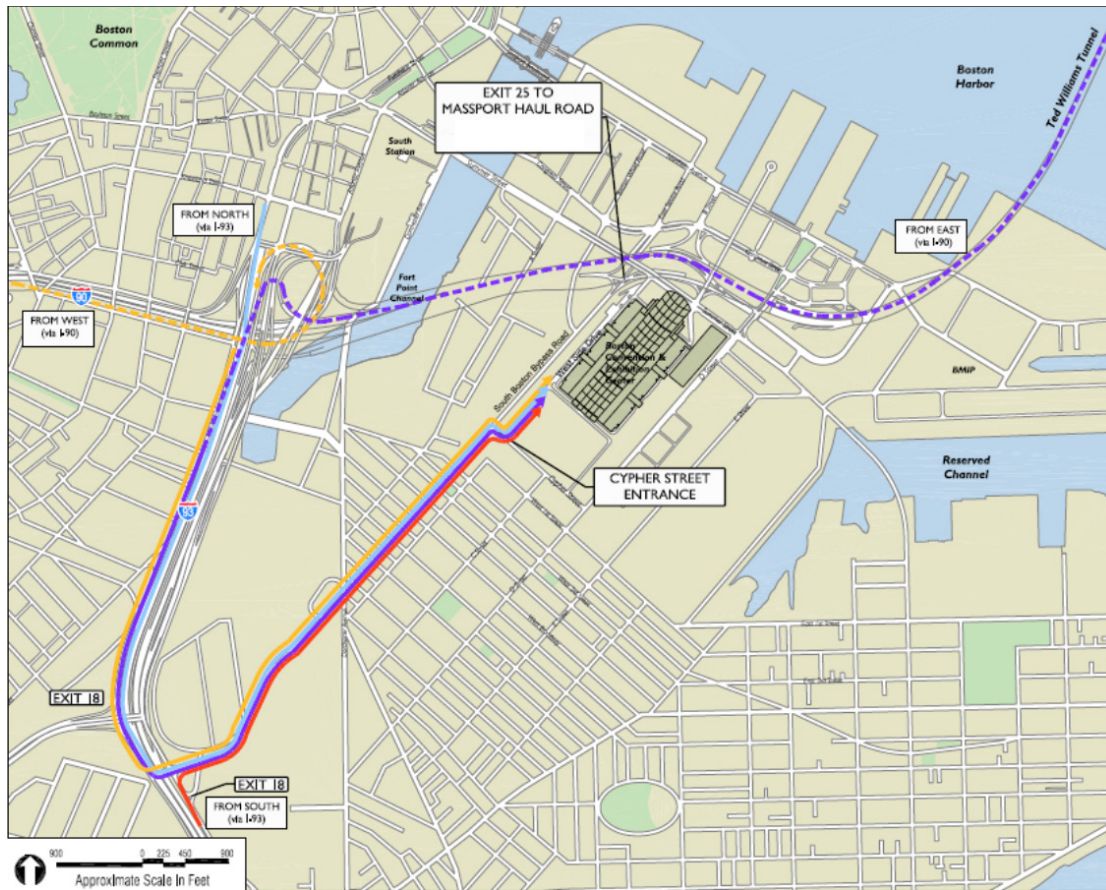

From the South:

- Take I-93 Northbound to Exit 18
- Take a right at second traffic light (South Boston Bypass Road)
- Follow South Boston Bypass Road for approximately one mile
- Take a right into Cypher Street and a left into West Side Drive

From the North:

- Take I-93 Southbound to Exit 18
- Take a left at second traffic light (South Boston Bypass Road)
- Follow South Boston Bypass Road for approximately one mile
- Take a right into Cypher Street and a left into West Side Drive

From the West:

- Take I-90 Eastbound to I-93 Southbound
- Take I-93 Southbound to Exit 18
- Take a left at second traffic light (South Boston Bypass Road)
- Follow South Boston Bypass Road for approximately one mile
- Take a right into Cypher Street and a left into West Side Drive

From the East/Ted Williams Tunnel:

- Take Ted Williams Tunnel (90 East) to Exit 25 South Boston
- Take a left onto Congress Street
- Take a left onto West Service Road
- Take a right onto South Boston Bypass Road
- Take a left into Cypher Street and a left into West Side Drive

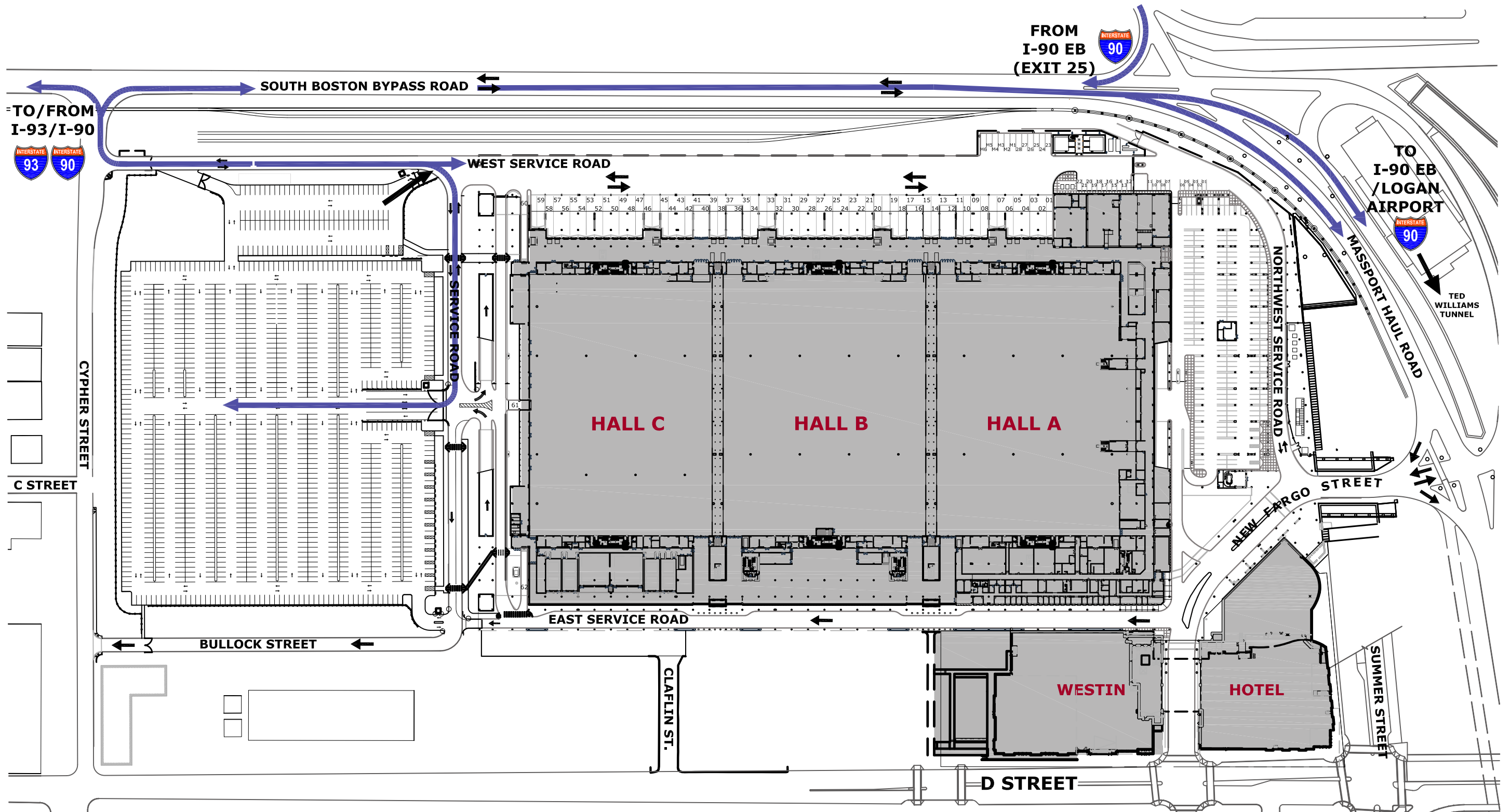

FREEMAN

(888) 508-5054 Fax: (469) 621-5608
ExhibitorSupport@freeman.com

NAME OF SHOW: **DBC PRI-MED EAST / DECEMBER 9 - 11, 2021**

COMPANY NAME: _____ BOOTH #: _____

CONTACT NAME : _____ PHONE #: _____

E-MAIL ADDRESS : _____

For fast, easy ordering, go to www.freeman.com/store.

EVERY OUTBOUND SHIPMENT WILL REQUIRE A MATERIAL HANDLING AGREEMENT AND SHIPPING LABELS. WE WOULD BE HAPPY TO PREPARE THESE FOR YOU AND DELIVER THEM TO YOUR BOOTH PRIOR TO SHOW CLOSE. TO TAKE ADVANTAGE OF THIS SERVICE, PLEASE COMPLETE AND RETURN THIS FORM TO THE FREEMAN SERVICE CENTER.

SHIPPING INFORMATION

SHIP TO: COMPANY NAME: _____

DELIVERY ADDRESS: _____

CITY: _____ STATE/ PROVINCE: _____ ZIP/ POSTAL CODE: _____

PHONE#: _____ ATTN: _____

SPECIAL INSTRUCTIONS: _____

BILL TO: Same as Ship to:

COMPANY NAME: _____

DELIVERY ADDRESS: _____

CITY: _____ STATE/ PROVINCE: _____ ZIP/ POSTAL CODE: _____

METHOD OF SHIPMENT

Select a Carrier:

Freeman Exhibit Transportation **Other Carrier**

No need to schedule your outbound shipment.
Charges will appear on your Freeman invoice.

Carrier Name: _____

Carrier Phone: _____

Freeman will make arrangements for all Freeman Exhibit Transportation shipments.
Arrangements for pick-up by other carriers is the responsibility of the exhibitor.

Select a Level of Service:

- 1 Day: Delivery next business day Standard Ground
 2 Day: Delivery by 5:00 PM second business day Specialized: Pad wrapped, uncrated, or truckload
 Deferred: Delivery within 3-5 business days

Select Shipment Options (if applicable)

- Have loading dock Lift gate required
 Inside delivery Air ride required
 Pad wrap required Residential
 Do not stack

Select Desired Number of Labels: _____

Once your shipment is packed and ready to be picked up from your booth, please return completed the Material Handling Agreement to the Freeman Service Center. Shipments without a Material Handling Agreement turned in will be returned to our warehouse at exhibitor's expense.

F R E E M A N

R U S H

DO NOT DELAY

F R E E M A N

R U S H

DO NOT DELAY

RECEIVING DATE BEGINS: NOVEMBER 08, 2021

RECEIVING DATE BEGINS: NOVEMBER 08, 2021

DEADLINE DATE IS: NOVEMBER 30, 2021

DEADLINE DATE IS: NOVEMBER 30, 2021

TO: _____

EXHIBITOR NAME

TO: _____

EXHIBITOR NAME

**C/O: TFORCE FREIGHT / FREEMAN
80 CONCORD ST**

**C/O: TFORCE FREIGHT / FREEMAN
80 CONCORD ST**

NORTH READING, MA 01864

NORTH READING, MA 01864

WAREHOUSE

(482955)

WAREHOUSE

(482955)

EVENT: **DBC PRI-MED EAST**

EVENT: **DBC PRI-MED EAST**

BOOTH NO: _____ **NO.** _____ **OF** _____ **PCS**

BOOTH NO: _____ **NO.** _____ **OF** _____ **PCS**

THE ABOVE LABELS ARE PROVIDED FOR YOUR CONVENIENCE.
PLACE ONE ON EACH PIECE SHIPPED TO ENSURE PROPER DELIVERY.
IF MORE LABELS ARE NEEDED, COPIES ARE ACCEPTABLE.

F R E E M A N

F R E E M A N

R U S H

R U S H

DO NOT DELAY

DO NOT DELAY

CANNOT DELIVER BEFORE DECEMBER 07, 2021

CANNOT DELIVER BEFORE DECEMBER 07, 2021

TO: _____
EXHIBITOR NAME

TO: _____
EXHIBITOR NAME

C/O: FREEMAN
BOSTON CONVENTION & EXHIBITION CENTI
415 SUMMER ST

BOSTON, MA 02210

C/O: FREEMAN
BOSTON CONVENTION & EXHIBITION CENTE
415 SUMMER ST

BOSTON, MA 02210

SHOW SITE

(482955)

SHOW SITE

(482955)

EVENT: _____ **DBC PRI-MED EAST**

EVENT: _____ **DBC PRI-MED EAST**

BOOTH NO: _____ NO. _____ OF _____ PCS

BOOTH NO: _____ NO. _____ OF _____ PCS

THE ABOVE LABELS ARE PROVIDED FOR YOUR CONVENIENCE.
PLACE ONE ON EACH PIECE SHIPPED TO ENSURE PROPER DELIVERY.
IF MORE LABELS ARE NEEDED, COPIES ARE ACCEPTABLE.

Exhibitor support

Visit us at freeman.com or call 1.888.508.5054 to speak to our award winning exhibitor support team.

Freeman® Trade Show Furnishings are proud to offer this collection of the highest quality, design-oriented furnishings. Our nationwide distribution and professional staff is dedicated to the success of your exhibit. Make Freeman® Trade Show Furnishings your furniture solution.

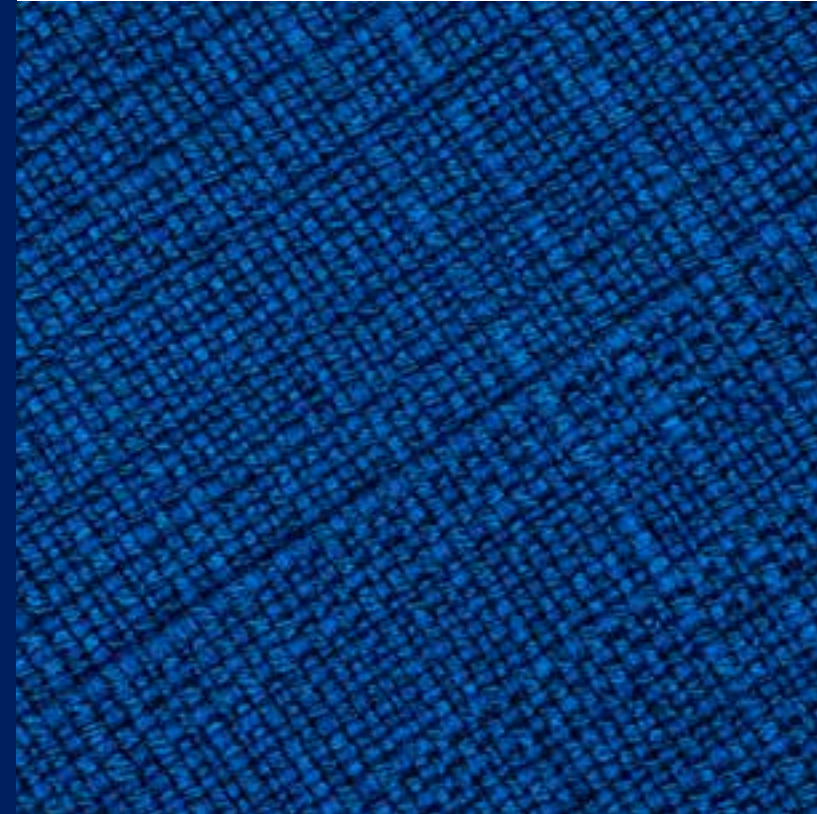

Furnishings Brochure



Comfortable and Safe Networking

Meaningful engagement doesn't have to be complicated.

Networking and connecting with peers face-to-face is a key objective of attending in-person events. Delivering environments which facilitate both ad-hoc and in-depth networking is important in accommodating attendee needs and will allow attendees to connect with peers effectively, comfortably, and safely.

To help you feel confident as you begin to plan your in-person and hybrid events, we have developed Freeman SafeConnect. This program includes standards, protocols, and service offerings that reflect our values and commitment to safety and wellbeing — for our people, our customers, and our attendees.

Learn more about Freeman SafeConnect at [Freeman.com](https://freeman.com)



Bowery Swivel Chairs & Sedona C-Tables

Accent Chairs | pg 16
Side Tables | pg 28
Dividers | pg 57
Greenery | pg 48

Top Design Tips

for Tradeshow Booths.

10.

Provide a Pop!
Colorful furnishings attract attention and help reinforce brand themes.



1.

Spin Around.
Swivel chairs in small spaces maximize functionality and allow you to engage with those all around!

2.

Get Connected.
Communal tables help facilitate networking opportunities and build connections.



9.

Charge it!
Powered tables and seating encourages clients to linger in the booth and recharge.



8.

Gather Round!
Ottomans styled around a side table create an informal campfire setting for small group discussions.



3.

Creature Comforts.
Design a comfortable "living room" space with soft lounge seating to relax clients and encourage conversation.

4.

Keep it Green.
Don't forget the greenery to warm up your booth environment by bringing nature indoors.



7.

Stay Social.
Stylize furnishings to create shareable moments worthy of Instagram.



6.

Level the field!
Low and casual seating makes clients more comfortable and open to learning.



5.

Demo Down.
Square or circular ottomans are a great way to design small theaters for quick demonstrations.



Complete The Look Of Your Exhibit Space

Freeman makes it easy to furnish your next exhibit space with recommended booth packages available on FreemanOnline. To view all available booth packages for your event and order your favorite, visit freeman.com/store.



The Showcase 10'x10' booth package is designed for exhibitors with small, high value items to display. Multiple cabinets elevate your products and make it easy to catch the eye of attendees.

Shown here with **Zoey Barstools**

The Cinematic 10'x20' booth package is designed for exhibitors needing large monitors to display presentations, while hosting attendees in a comfortable and inviting environment.

Shown here with **Banana Barstools**



The Gather 10'x10' booth package turns your booth into a comfortable oasis from the bustle of the show floor. Ideal for comfortable one-on-one time with prospects.

Shown here with **Baja Chairs and Sydney Power Cocktail Table**

Power Up In Style.

Denotes Powered Products 

Powered Seating

Empower attendees at your next show with functional charging furniture and make searching for wall outlets history. From soft seating and tables to pedestals and lamps, our complete charging collection lets you Power Up the Possibilities.



HEDGE
85035
4' Boxwood Hedge
46"L 9"D 47"H



NAPLES 
830121
Naples Sofa, Powered
(black vinyl)
87"L 30"D 33.25"H

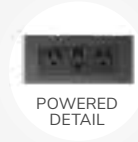

NAPLES 
810120
Naples Chair, Powered
(black vinyl)
36"L 30"D 33.25"H



NAPLES 
830122
Naples Loveseat, Powered
(black vinyl)
62"L 30"D 33.25"H





Powered Tables

Use
Ventura 6'
Bar or Cafe Tables
in your design to
facilitate conversations
while social
distancing.

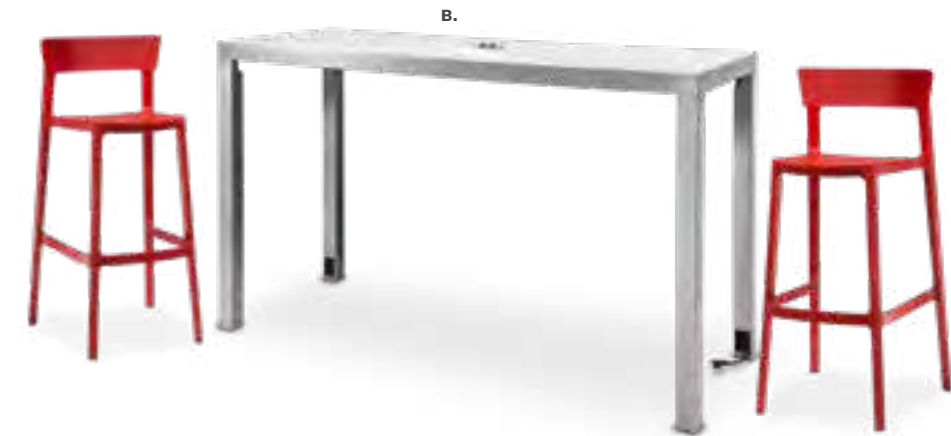
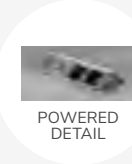

**Ventura Powered
Bar Tables**
72.25"L 26.25"D 42"H
(silver frame)
A) 820950 (black top)
B) 820955 (white top)



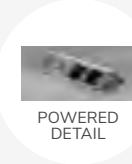

**Ventura Powered
Café Tables**
72.25"L 26.25"D 30"H
(silver frame)
C) 820964 (black top)
D) 820965 (white top)



Please Note: Customer is responsible for providing labor and an electrical power source to the furniture. One 110V power source is required for each charging panel. Two charging units can be daisy chained together. 10A max per charging panel.

Take Charge.

Denotes Powered Products 

Powered Tables

Empower attendees at your next show with functional charging furniture and make searching for wall outlets history. From soft seating and tables to pedestals and lamps, our complete charging collection lets you Power Up the Possibilities.

SYDNEY 
Sydney Powered Cocktail Tables
 48"L 26"D 18"H (brushed steel)
E) 82073 (white)
F) 82076 (black)



Please Note: Customer is responsible for providing labor and an electrical power source to the furniture. One 110V power source is required for each charging panel. Two charging units can be daisy chained together. 10A max per charging panel.

Powered Pedestals

Denotes AC and USB charging outlets 

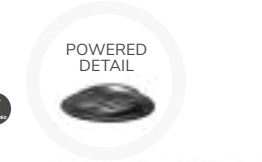
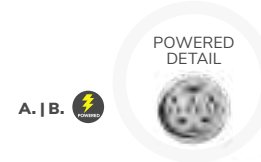

Powered Locking Pedestal
 (white)
A) 85061 24"L 24"D 36"H
B) 85063 24"L 24"D 42"H (black)
C) 85060 24"L 24"D 36"H
D) 85062 24"L 24"D 42"H

(The flip top electrical units rotate 180 degrees, allowing devices to be charged from inside the locked cabinet or on the surface.)

Powered Tech Desk

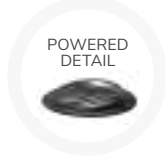

A) 84083 Tech Desk, Powered w/ 3 Drawer File Cabinet
 (black metal, laminate)
 60"L 30"D 30"H

B) 84084 Tech Desk, Powered
 (black metal, laminate)
 60"L 30"D 30"H

C) 84080 3 Drawer File Cabinet on Castors
 (black metal, laminate)
 16"L 20"D 28"H

Take Charge.

Denotes Powered Products 

Powered Tech Tablet Chair

Create an engaged learning environment at your next exhibit with the exclusive, powered Tech Tablet Chair. The soft dove gray vinyl chair features a removable white swivel tablet, an under-seat shelf for personal storage and an in-arm charging panel with three USB ports. An additional AC outlet is located at the base of the chair.

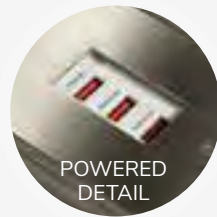

- A) **81039 Tech Tablet Chair**
(gray vinyl, white metal tablet, chrome base)
30.5"L 29"D 33.5"H
- B) **81038 Tech Chair, No Tablet**



Please Note: Customer is responsible for providing labor and an electrical power source to the furniture. One 110V power source is required for each charging panel. Two charging units can be daisy chained together. 10A max per charging panel.

Powered Products

Denotes AC and USB charging outlets 

Wireless Charging Table



-  **820710 Wireless Charging Table, Powered**
(white, AC plug-in)
20"L 20"D 18"H
Mobile devices must have Qi wireless charging capability.



Village Charging Hub

-  **8502 Village Charging Hub**
(cream)
12"L 12"D 28.25"H

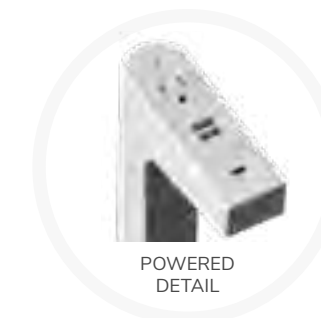

Please Note: Customer is responsible for providing labor and an electrical power source to the furniture. One 110V power source is required for each charging panel. Two charging units can be daisy chained together. 10A max per charging panel.

Soft Seating

Create Engaging Booth Environments

VALENCIA

810180 Chair
(spice orange velvet)
28"L 30.5"D 31"H
83045 Sofa
(coffee brown velvet)
63"L 30.5"D 31"H

MARCHE
81540 Swivel Ottoman
(Forest Green Vinyl)
17"RND 18"H



Valencia Sofa & Chair 10'x10' Booth

HEDGE

85035
4' Boxwood Hedge
46"L 9"D 47"H



VALENCIA

A) 810180 Chair
(spice orange velvet)
28"L 30.5"D 31"H
B) 83045 Sofa
(coffee brown velvet)
63"L 30.5"D 31"H

Soft Seating Collections



BAJA

A) 83019 Sofa
(white vinyl)
86"L 28"D 30"H

B) 81050 Chair
(white vinyl)
36"L 30.5"D 28"H

C) 83020 Loveseat
(white vinyl)
61"L 30.5"D 28"H



STERLING

A) 8309 Sofa
(gray fabric)
82"L 33.5"D 32"H

B) 81037 Chair
(gray fabric)
33"L 33.5"D 32"H



KEY LARGO

A) 830951 Sofa
(black fabric)
79"L 35"D 34"H

B) 810950 Chair
(black fabric)
35"L 35"D 34"H

C) 830950 Loveseat
(black fabric)
57"L 35"D 34"H

Soft Seating

Denotes Powered Products 

Create Engaging Booth Environments

HEDGE
85035
4' Boxwood Hedge
46"L 9"D 47"H

PALM BEACH
83040 Sofa
(white vinyl, brushed metal)
69"L 29"D 33"H

SWANSON
810875 Swivel Chair
(white vinyl)
28"L 25"D 30"H



Palm Beach Sofa & Swanson Chairs 10'x10' Booth



PALM BEACH
83040 Sofa
(white vinyl, brushed metal)
69"L 29"D 33"H

Soft Seating Collections

Available in Power 



ALLEGRO
A) 81019 Chair
(blue fabric)
36"L 34.5"D 30"H
B) 83015 Sofa
(blue fabric)
73"L 34.5"D 30"H



FAIRFAX
A) 830949 Sofa
(white vinyl, brushed metal)
62"L 26"D 30"H
B) 810949 Chair
(white vinyl, brushed metal)
27"L 26"D 30"H



NAPLES 
A) 810119 Chair
(black vinyl)
36"L 30"D 33.25"H
810120 (Powered)
B) 830119 Sofa
(black vinyl)
87"L 30"D 33.25"H
830121 (Powered)
C) 830120 Loveseat
(black vinyl)
62"L 30"D 33.25"H
830122 (Powered)

Accent Chairs

Create Space

Swivel chairs maximize functionality and allow you to engage safely with those all around. They're particularly helpful in smaller spaces!



81034
Bowery Swivel Chair
(ochre fabric, chrome)
29.75"L 31"D 27.25"H



810875
Swanson Swivel Chair
(white vinyl)
28"L 25"D 30"H



810874
La Brea Chair
(charcoal gray, fabric)
35"L 27"D 40"H



810145
Wentworth Chair
(brown vinyl)
32.1"L 26"D 31.5"H

Meeting & Stage Chairs



Marina Chair
17.5"L 19.5"D 35"H
A) 810164 (white vinyl)
B) 810160 (black vinyl)
C) 810161 (brown fabric)



810948
Meeting Chair
25.5"L 23.5"D 34"H
(white vinyl)

Accent Chairs

Accent Chair Styles



Madrid
810816 Chair
(white, chrome)
30"L 30"D 31"H



Montreal
81031 Chair
(blue, black metal)
30"L 23.25"D 30"H



Accent Tables | pg 26



Lena
81036 Chair
(moss green leather, bronze)
27"L 25"D 31"H



810949
Fairfax Chair
(white vinyl, brushed metal)
27"L 26"D 30"H



A) 810151
Munich Armless Chair
(gray fabric)
22.5"L 27"D 28.5"H

B) 81035
Century Chair
(gray velvet)
30"L 30"D 31"H

C) 81024
Atherton Chair
(distressed brown leather,
blackened steel)
27"L 31"D 30"H

D) 810947
Pro Executive
Guest Chair
(black vinyl)
24"L 26"D 36"H

E) 81032
Pasadena Chair
(white molded plastic
w/ chrome tower base)
27"L 25"D 26"H

F) 81037
Sterling Chair
(gray fabric)
33"L 33.5"D 32"H



A.



B.



D.



E.



F.

Group Seating

Lounges

Carefully designed lounges deliver a safe and effective setting for casual and relaxed connections. The strategic placement of other furniture pieces—like coffee tables, room dividers, and large plants—helps to maintain order and preserve social distancing protocols while delivering comfortable and safe networking.

ZENITH

A) 810851 Chair
(white, chrome)
18.25"L 22"D 32"H

**B) 820241
Madison Hydraulic
Café Table**
(chrome base, gray
acajou top)
30"RND 29"H



LAGUNA

C) 810861 Chair
(maple, chrome)
18"L 19"D 34"H

**D) 8201223
Round Café Table**
(white laminate top,
chrome hydraulic base)
30" RND 29"H



MALBA

20"L 20"D 32"H
A) 810131 Chair (gray)
B) 810130 Chair (green)



MARINA

17.5"L 19.5"D 35"H
A) 810164 (white vinyl)
B) 810160 (black vinyl)
C) 810161 (brown fabric)
D) 810162 (ocean blue fabric)
E) 810163 (red fabric)



Styles & Shapes

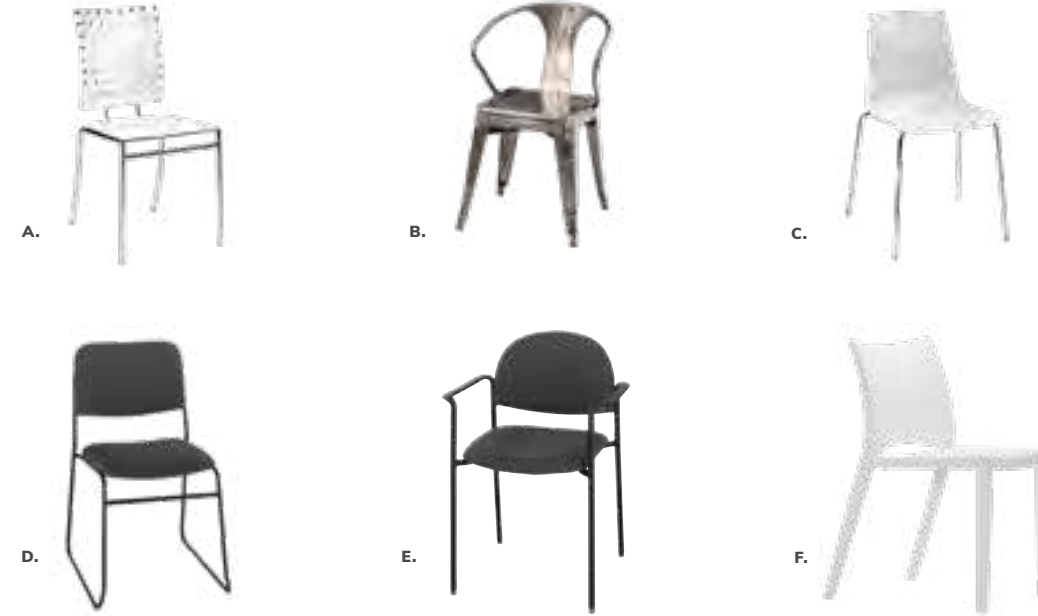

**A) 810846
Christopher Chair**
(white vinyl, chrome)
17"L 19"D 35"H

**B) 810841
Rustique Chair w/arms**
(gunmetal)
20"L 18"D 31"H

**C) 81093
Lucent Chair**
(frosted, acrylic)
19.5"L 19.75"D 32.5"H

**D) 71089
Diamond Side Chair**
(black)
21"W X 23"L X 32"H

**E) 71090
Diamond Arm Chair**
(black)
20"W X 21"L X 33"H

**F) 810837
Razor Armless Chair**
(white)
15.38"L 15.5"D 30.5"H

**G) 81083
Blade Chair**
(sky blue)
20.5"L 19"D 30.5"H

**H) 81082
Blade Chair**
(red)
20.5"L 19"D 30.5"H



Mix & Match

Create the ultimate seating configuration. Choose from a variety of shapes and sizes to design the perfect look.

I) 210108 LIMERICK® Chair BY HERMAN MILLER™
(gray) 18"W X 17.75"L X 33"H



Ottomans

Vibe Cube

18"L 18"D 18"H

- A) 81535 (citrus green vinyl)
- B) 81537 (spice orange vinyl)
- C) 81538 (desert rose vinyl)
- D) 81536 (taupe vinyl)
- E) 81531 (white vinyl)
- F) 81530 (black vinyl)
- G) 81532 (steel blue vinyl)
- H) 81534 (purple vinyl)
- I) 81533 (silver vinyl)
- J) 81519 (red vinyl)
- K) 81517 (yellow vinyl)
- L) 81518 (blue vinyl)
- M) 81525 (orange vinyl)

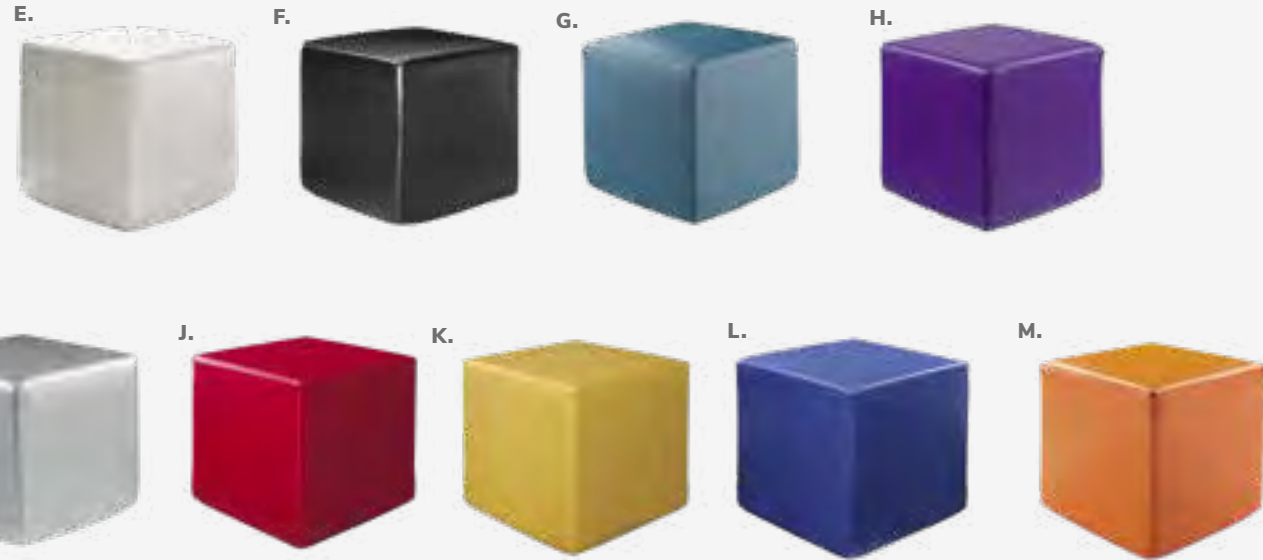

Beverly Bench Ottomans



- Beverly Bench**
60"L 20"D 18"H
- A) 81556 (white vinyl)
 - B) 81550 (black vinyl)
 - C) 81552 (gray fabric)
 - D) 81555 (red fabric)
 - E) 81554 (ocean blue fabric)
 - F) 81553 (linen fabric)
 - G) 81551 (brown fabric)

Styles & Shapes



- ENDLESS Square**
34"L 34"D 15"H
- A) 815123 (black)
 - B) 815122 (white)

- ENDLESS Curved**
60.5"L 37.5"D 15"H
- C) 815952 (black)
 - D) 815953 (white)



- E) 82074
Regis Bench
(brushed metal)
47"L 15.5"D 16"H

Ottomans

Beverly Small Bench Ottomans

30"L 20"D 18"H

- A) 81567 (orange fabric)
- B) 81563 (olive green fabric)
- C) 81569 (white vinyl)
- D) 81560 (black vinyl)
- E) 81561 (ocean blue fabric)
- F) 81562 (brown fabric)
- G) 81564 (gray fabric)
- H) 81565 (linen fabric)
- I) 81566 (lavender fabric)
- J) 81568 (red fabric)
- K) 81570 (yellow fabric)



Marche Swivel Ottomans



- Marche Swivel Ottomans**
17" RND 18"H
- A) 815150 (white vinyl)
 - B) 815154 (red fabric)
 - C) 81539 (Ivory Faux Sheep Fur)
 - D) 815158 (pear yellow fabric)
 - E) 815156 (plum fabric)
 - F) 815159 (blue fabric)
 - G) 815151 (gray fabric)
 - H) 815155 (rose quartz fabric)
 - I) 815152 (linen fabric)
 - J) 815153 (raspberry fabric)
 - K) 815157 (meadow green fabric)
 - L) 815160 (orange fabric)
 - M) 81543 (black vinyl)
 - N) 81540 (forest green vinyl)
 - O) 81541 (teal velvet)
 - P) 81542 (distressed brown vinyl)

Accent Tables

Tables and Meeting Rooms

When you want to facilitate more in-depth conversations and provide work surfaces, be sure to use appropriately-sized tables. As always, create generous aiseways between meetings spaces; this will help individuals feel comfortable networking.



MESA

A) 820135 End Table
20.5"RND 21.25"H (wood top, bronze)
B) 820132 Cocktail Table
32.25"RND 17.25"H (wood top, bronze)

C) 820134 End Table
24"RND 21.25"H (glass top, bronze)
D) 820131 Cocktail Table
36"RND 17.25"H (glass top, bronze)

E) 820133 End Table
20.5"RND 21.25"H (black top, bronze)
F) 820130 Cocktail Table
32.25"RND 17.25"H (black top, bronze)

Styles & Shapes



ALONDRA

Cocktail Table
47"L 24"D 16"H
A) 820250 (glass, chrome)
B) 820251 (wood, chrome)

End Table
20"L 20"D 20"H
C) 820252 (glass, chrome)
D) 820253 (wood, chrome)

GEO

Cocktail Table
50"L 22"D 16"H
A) 82034 (glass, chrome)
B) 82027 (wood, black)

End Table
26"L 26"D 20"H
C) 82035 (glass, chrome)
D) 82028 (wood, black)

Accent Tables

Tables and Meeting Rooms

TAOS SIDE TABLES

15.75"L 15.75"D 24"H
A) 820322
 (white top, bronze)
B) 820320
 (black top, bronze)
C) 820321
 (wood top, bronze)



SEDONA SIDE TABLE

15.75"L 15.75"D 24"H
D) 820312
 (white top, bronze)
E) 820310
 (black top, bronze)
F) 820311
 (wood top, bronze)



Styles & Shapes

Available in Power



SYDNEY

Cocktail Tables
 (brushed steel)
 48"L 26"D 18"H
A) 82053 (white)
82073 (powered)
B) 82052 (black)
82076 (powered)
C) 82077 (blue)
D) 82078 (wood)

End Tables
 27"L 23"D 22"H
E) 82055 (white)
F) 82054 (black)
G) 82079 (blue)
H) 82080 (wood)

REGIS

(brushed metal)
I) 82074 Bench Table
 47"L 15.5"D 16"H
J) 82075 End Table
 16"L 15.5"D 16.5"H

SILVERADO

(glass, chrome)
K) 82015 End Table
 24" RND 22"H
L) 82014 Cocktail Table
 36" RND 17"H

WIRELESS

M) Charging Table, Powered
N) 820710
 (white, AC plug-in)
 20"L 20"D 18"H

AURA

Round Table
N) 820844
 (white metal)
 15" Round 22"H

Café Tables



A) 820940 Blue Hydraulic Café Table
(chrome base, blue top) 30" RND 29"H
B) 810131 Malba Chair
(gray) 20"L 20"D 32"H



A) 820241 Madison Hydraulic Café Table
(chrome base, gray acajou top) 30" RND 29"H
B) 810130 Malba Chair
(green) 20"L 20"D 32"H

85030 7' Boxwood Hedge
36.5"L 12"D 84"H



30" Round Café Table
A) 820941 Standard Black Base (blue top) 30" RND 29"H
B) 81093 Lucent Chair (frosted, acrylic) 19.5"L 19.75"D 32.5"H



A) 8201233 Hydraulic Cafe Table
(orange top, chrome) 30" RND 29"H
B) 810861 Laguna Chair
(maple, chrome) 18"L 19"D 34"H

Customize and Create

Choose your base, black or chrome, then pick a color that suits your design.

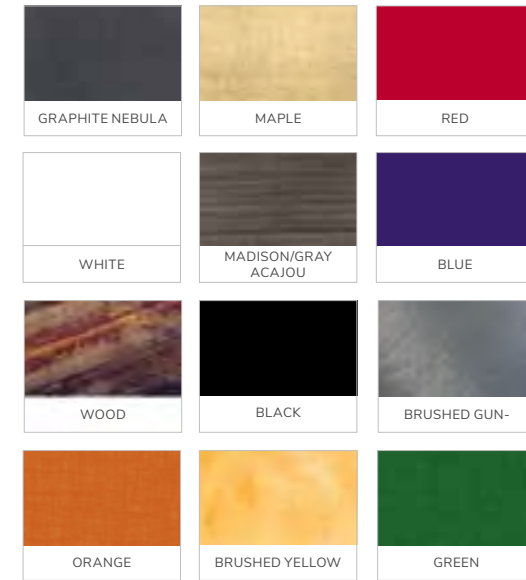

Café Tables Standard Black Base 30" RND 29"H

- A) 8201220** (white) also available
- 820265** (Madison/gray acajou)
- 820941** (blue)
- 820943** (wood)
- 8201236** (black)
- 8201235** (brushed gunmetal)
- 8201239** (brushed yellow)
- 8201237** (green)
- 8201238** (orange)

36" RND 29"H
8201243 (black)

Café Tables Hydraulic Chrome Base 30" RND 29"H

- B) 820923** (graphite nebula) also available
- 8201208** (maple)
- 820921** (red)
- 820940** (blue)
- 820942** (wood)
- 8201223** (white)
- 8201231** (black)
- 8201230** (brushed gunmetal)
- 8201234** (brushed yellow)
- 8201232** (green)
- 8201233** (orange)

36" RND 29"H
820126 (white)
8201209 (graphite nebula)
8201206 (maple)
8201242 (black)

Mix & Match

Create your look. Choose from a wide variety of tables and seating options.



C) 72063 Chelsea Butcher Block-Top Café Table
(oak) 30" RND 30"H
also available
72064 36" RND 30"H

D) 810164 Marina Chair
(white vinyl) 17.5"L 19.5"D 35"H

E) 72069 Soho Black-Top Café Table
(black) 24" RND 30"H
also available
72067 36" RND 30"H | **72066** 18" RND 18"H

F) 81082 Blade Chair
(red) 20.5"L 19"D 30.5"H



Bar Tables

A) 8201222 30" Round Bar Table
(white top, chrome hydraulic base) 30" RND 45"H
B) 81080 Blade Barstool (red) 20.5"L 20.125"D 40.5"H



C) 8201226 Rustique Square Metal Bar Table
(gunmetal) 23.75"L 23.75"D 41.25"H
D) 810839 Rustique Barstool
(gunmetal) 13"L 13"D 30"H



E) 820930 30" Round Bar Table
(blue top, chrome hydraulic base) 30" RND 45"H
F) 810860 Laguna Barstool (maple, chrome) 18"L 20"D 47"H



G) 820240 30" Round Bar Table w/ Hydraulic Chrome Base
(Madison/gray acajou) 30" RND 45"H
H) 810848 Christopher Barstool (white vinyl, chrome) 19"L 15"D 41"H



Customize and Create

Choose your base, black or chrome, then pick a color that suits your design.

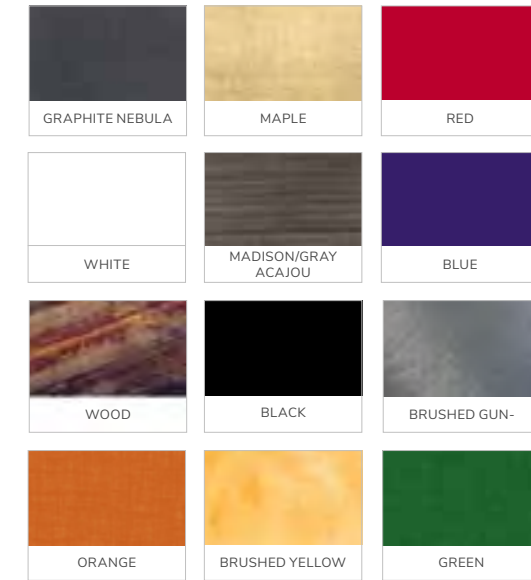

Bar Tables Standard Black Base 30" RND 42"H

A) 8201221 (white)
B) 820919 (brushed yellow)
also available
820264
(Madison/gray acajou)
820915 (brushed gunmetal)
820916 (black)
820917 (green)
820918 (orange)
820931 (blue)
820933 (wood)

36" RND 42"H
8201241 (black)

Bar Tables Hydraulic Chrome Base 30" RND 45"H

C) 820920 (red)
also available
8201207 (maple)
820922
(graphite nebula)
820910 (brushed gunmetal)
820911 (black)
820912 (green)
820913 (orange)
820914 (brushed yellow)
820930 (blue)
820932 (wood)
8201236 (black)

36" RND 45"H
820125 (white)
8201211 (graphite nebula)
8201205 (maple)
8201240 (black)

Style & Design

Choose from a variety of table top colors and styles for the perfect look.



C) 720163 Chelsea Butcher Block-Top Bistro Table
(oak) 30" RND 42"H
also available
720164 36" RND 42"H

D) 81092 Lucent Barstool
(frosted, acrylic) 22"L 22.5"D 45.5"H

E) 72070 Soho Black-Top Bistro Table
(black) 24" RND 42"H
also available
72068 36" RND 42"H

F) 810840 Zoey Barstools
(white, chrome)
15"L 16"D 30-34.75"H



Barstools

LIFT Barstools

- 15" RND 23-33.5"H
A) 810870 (white vinyl)
B) 810873 (red vinyl)
C) 810871 (black vinyl)
D) 810872 (gray vinyl)



Marina Barstools



Marina Barstools
21"L17.5"D41.5"H

- A) 81026 (ocean blue fabric)
B) 81028 (brown fabric)
C) 81029 (red fabric)
D) 81030 (white vinyl)
E) 81027 (black vinyl)

All frames brushed metal.

Barstools

Mix & Match

A) 810840
Zoey Barstools
 (white, chrome)
 15"L 16"D 30-34.75"H

Banana Barstools
 21"L 22"D 41.75"H
B) 810104 (black, chrome)
C) 810103 (white, chrome)

D) 810848
Christopher Barstool
 (white vinyl, chrome)
 19"L 15"D 41"H

E) 810202
Shark Barstool
 (white, chrome)
 22"L 19"D 34-44"H

F) 810850
Zenith Barstool
 (white, chrome)
 19"L 20"D 44"H

G) 81092
Lucent Barstool
 (frosted, acrylic)
 22"L 22.5"D 45.5"H



210109 LIMERICK®
Stool BY HERMAN MILLER™
 (white) 18" X 17.75"L X 44"H



720163
Butcher Block-Top Bistro
 (oak) 30"L RND 42"H
 also available
720164 36" RND 42"H

Barstools Styles & Shapes



H) 810860
Laguna Barstool
 (maple, chrome)
 18"L 20"D 47"H

Blade Barstool
 20.5"L 20.125"D 40.5"H
I) 81080 (red)
J) 81081 (sky blue)

K) 71088
Black Diamond Stool
 (black) 22"W X 18"L X 46"H

L) 810839
Rustique Barstool
 (gunmetal)
 13"L 13"D 30"H

Conference Tables

42" Round Conference Table

42"RND 29"H
A) 820708 (white laminate)
B) 820260 (Madison/gray acajou)
C) 8201244 (black top, black)



Atomic Round Tables
 (glass, chrome)
8201225 42" RND 30"H
8201224 36" RND 30"H

Pro Executive Mid Back Chair
 24"L 22"D 40"H
A) 810945 (white vinyl)
B) 810944 (black vinyl)
 Adjustable height



Geo Tables



Geo Rectangular Tables
 60"L 36"D 29"H
E) 82041 (glass, black)
F) 82051 (glass, chrome)

Geo Rounded Square Tables
 42"L 42"D 29"H
G) 82044 (glass, chrome)
H) 82043 (glass, black)

Work Space



I) 820706 Work Table
 (white laminate, white)
 48"L 24"D 30"H

Conference Tables

Madison

(Madison/gray acajou)
A) 820261 5' Table
 60"L 48"D 29"H

B) 820262 8' Table
 96"L 60"D 29"H

C) 820263 10' Table
 120"L 48"D 29"H



810175 Genesis Chair
 (black fabric, black)
 27.5"L 27.5"D 40-43.5"H Adjustable.

Black Rectangular Conference Table



810170 Cupertino Mid Back Chair
 (black vinyl, chrome)
 27"L 30.5"D 40-43"H Adjustable.

Black Rectangular Conference Table
 (black top, silver)

A) 8203 5' Table
 60"L 48"D 29"H
8204 Powered

B) 8205 8' Table
 96"L 48"D 29"H
8206 Powered

C) 8201 10' Table
 120"L 48"D 29"H
8202 Powered

Executive Seating

Pro Executive High Back Chair

25"L 24"D 48"H
A) 810844 (white vinyl)
B) 810946 (black vinyl)
 Adjustable height



Cupertino Mid Back Chair

A) 810170 (black vinyl, chrome) 27"L 30.5"D 40-43"H Adjustable.

Genesis Chair

B) 810175 (black fabric, black) 27.5"L 27.5"D 40-43.5"H Adjustable.

Pro Executive Mid Back Chair

24"L 22"D 40"H
A) 810945 (white vinyl)
B) 810944 (black vinyl)
 Adjustable height



Pro Executive Guest Chair

24"L 22"D 36"H
810947 (black vinyl)



Task Stool

810135
 (black fabric)
 27.5"L 27.5"D 32.75"-40.25"H
 Adjustable height



Communal and Powered Tables

Choose from a variety of powered, solid or grommet hole table tops.

Table Top Options



Colors not available in all table options. Please check options listed to the right.

Denotes AC and USB charging outlets



POWERED DETAIL

Bar Tables

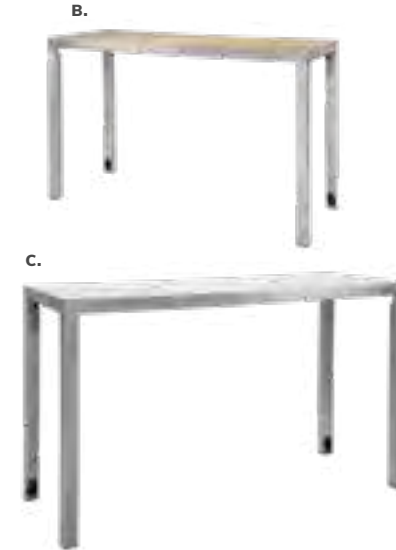

810860
Laguna Barstool
 (maple, chrome)
 18"L 20"D 47"H

Café Tables

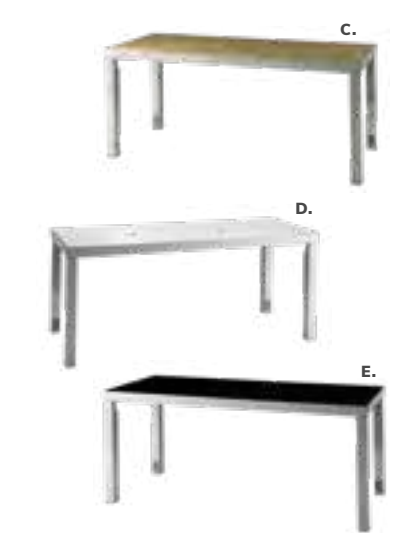

Ventura Powered Bar Tables

(silver frame)
 72.25"L 26.25"D 42"H
A) 820950 (black top)
B) 820955 (white top)

Ventura Communal Bar Tables

(silver frame)
 72.25"L 26.25"D 42"H
 Maple Top
B) 820954 (solid)
820951 (grommets)
 White Top
C) 820953 (grommets)
820956 (solid)
 Black Top
820952 (solid)

Ventura Powered Café Tables

(silver frame)
 72.25"L 26.25"D 30"H
A) 820964 (black top)
B) 820965 (white top)

Ventura Communal Café Tables

(silver frame)
 72.25"L 26.25"D 30"H
 Maple Top
C) 820963 (solid)
820960 (grommets)
 White Top
D) 820961 (grommets)
820966 (solid)
 Black Top
E) 820962 (solid)

Please Note: Customer is responsible for providing labor and an electrical power source to the furniture. One 110V power source is required for each charging panel. Two charging units can be daisy chained together. 10A max per charging panel.

Office Essentials



A.
DESK BACK

B.



DESK FRONT

MADISON

A) 84075 Madison Executive Desk
(gray acajou) 60"L 30"D 29"H

B) 810844 Pro Executive High Back Chair
(white classic vinyl) 25"L 24"D 48"H Adjustable

Tech Powered Desk

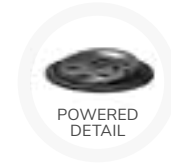

A. ⚡



C.

B. ⚡



Denotes AC and USB charging outlets

A) 84083 Tech Desk, Powered, w/ 3 Drawer File Cabinet
(black metal, laminate)
60"L 30"D 30"H

B) 84084 Tech Desk, Powered
(black metal, laminate)
60"L 30"D 30"H

C) 84080 3 Drawer File Cabinet on Castors
(black metal, laminate)
16"L 20"D 28"H

Please Note: Customer is responsible for providing labor and an electrical power source to the furniture. One 110V power source is required for each charging panel. Two charging units can be daisy chained together. 10A max per charging panel.

Lighting & Shelving

A.



B.



C.



D.



ACCENT LAMPS

Mason Lamps
(brushed silver)

A) 850708 Floor Lamp
18" RND 55"H

B) 850707 Table Lamp
16" RND 26"H

SHELVING

C) 85020

Posh Shelving
(chrome, acrylic)

36"L 18"D 72"H

D) 84078

Madison Bookcase
(gray acajou)

36"L 12"D 72"H

Show Essentials

Denotes AC and USB charging outlets 

Midtown Powered Counter

Metallic pewter gray curved counter with taupe-colored glass top features two AC outlets, three USB charging outlets, locking storage cabinet and two shelves.

 **Midtown Powered Counter**
60"L 18"D 42"H (pewter/glass)
850103 (unlighted)
850102 (lighted with plug-in)

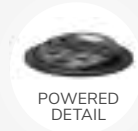
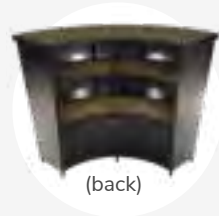

85030
7' Boxwood Hedge
36.5"L 12"D 84"H



810860
Laguna Barstool
(maple, chrome)
18"L 20"D 47"H

Midtown Bar

Metallic pewter gray curved bar with taupe-colored glass top features locking cabinet for storage and two shelves.

Midtown Bar
60"L 18"D 42"H (pewter)
A) 850101 (unlighted)
B) 850100 (lighted with plug-in)

C) 810840 Zoey Barstools
(white, chrome)
15"L 16"D 30-34.75"H

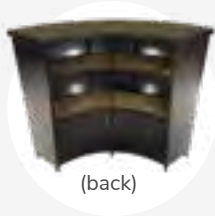

Please Note: Customer is responsible for providing labor and an electrical power source to the furniture. One 110V power source is required for each charging panel. Two charging units can be daisy chained together. 10A max per charging panel.

Product Display Counter



A) 72056
Display Counter
(black)
24"W X 49"L X 42"H

B) 210109
LIMERICK® Stool
BY HERMAN MILLER™
(white)
18" X 17.75"L X 44"H

Please Note: Customer is responsible for providing labor and an electrical power source to the furniture. One 110V power source is required for each charging panel. Two charging units can be daisy chained together. 10A max per charging panel.

Show Essentials

Greenery and Dividers

Metallic pewter gray curved counter with taupe-colored glass top features two AC outlets, three USB charging outlets, locking storage cabinet and two shelves.

HEDGE

- A) 85030
7' Boxwood Hedge
36.5"L 12"D 84"H
- B) 85035
4' Boxwood Hedge
46"L 9"D 47"H



Miramar Dividers



A.

B.

C.



- B) 820930
30" Round Bar Table
(blue top, chrome hydraulic base)
30" RND 45"H
- C) 810860 Laguna Barstool
(maple, chrome)
18"L 20"D 47"H

Miramar Dividers
(molded plastic)
A) 85040 (white)
Vertical: 63"L 23"D 83"H
Horizontal: 83"L 23"D 63"H

D.



E.



F.

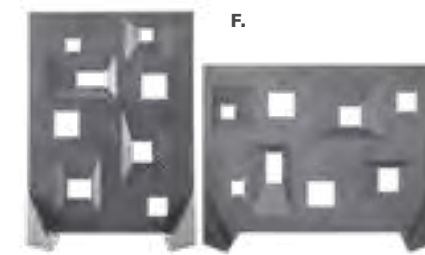

Miramar Dividers
(molded plastic)
D) 85043 (harvest yellow)
E) 85042 (burgundy)
F) 85041 (gray)
Vertical: 63"L 23"D 83"H
Horizontal: 83"L 23"D 63"H

Show Essentials

Product Kiosk & Display

A) 75032
Display Cube—Large
 (black)
 24"W X 24"L X 42"H

B) 75031
Display Cube—Medium
 (black)
 18"W X 18"L X 36"H

C) 75030
Display Cube—Small
 (black)
 12"W X 12"L X 42"H



Stanchions & Signage

A) 220121
Chrome Stanchion
 w/ 8' Retractable Belt
 (black, belt) 42"H

B) 220118
Chrome Sign Holder
 (sign holds)
 22"W X 28"H



Draped or Undraped Tables & Counters

Table Drape Colors

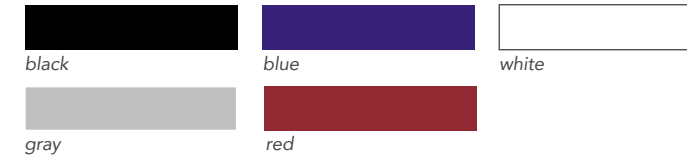

Visit us at freeman.com/store to view full product line and place order.



Sizing Chart*

24"D X 30"H | Tables Draped

124330 Tables Draped **3'L** x 24"D x 30"H
124430 Tables Draped **4'L** x 24"D x 30"H
124630 Tables Draped **6'L** x 24"D x 30"H
124830 Tables Draped **8'L** x 24"D x 30"H

24"D X 42"H | Counter Draped

124342 Counter Draped **3'L** x 24"D x 42"H
124442 Counter Draped **4'L** x 24"D x 42"H
124642 Counter Draped **6'L** x 24"D x 42"H
124842 Counter Draped **8'L** x 24"D x 42"H

24"D X 30"H | Tables Undraped

125330 Tables Undraped **3'L** x 24"D x 30"H
125430 Tables Undraped **4'L** x 24"D x 30"H
125630 Tables Undraped **6'L** x 24"D x 30"H
125830 Tables Undraped **8'L** x 24"D x 30"H

24"D X 42"H | Counter Undraped

125342 Counter Undraped **3'L** x 24"D x 42"H
125442 Counter Undraped **4'L** x 24"D x 42"H
125642 Counter Undraped **6'L** x 24"D x 42"H
125842 Counter Undraped **8'L** x 24"D x 42"H

4th Side | Table Draped 30"

12404630 Drape Table 4th Side **6' X 30"**
12404830 Drape Table 4th Side **8' X 30"**

4th Side | Table Draped 42"

12404642 Drape Table 4th Side **6' X 42"**
12404842 Drape Table 4th Side **8' X 42"**

Show Essentials

Storage



750135
Round Literature Rack
(black)
17"W X 17"L X 57"H



750136
Flat Literature Rack
(black)
10"W X 55"H

8503001
Large Refrigerator
(white) 14.0 cubic feet
28"W X 28"L X 64"H



84080
3 Drawer File Cabinet on Castors
(black metal, laminate)
16"L 20"D 28"H



Office Accessories

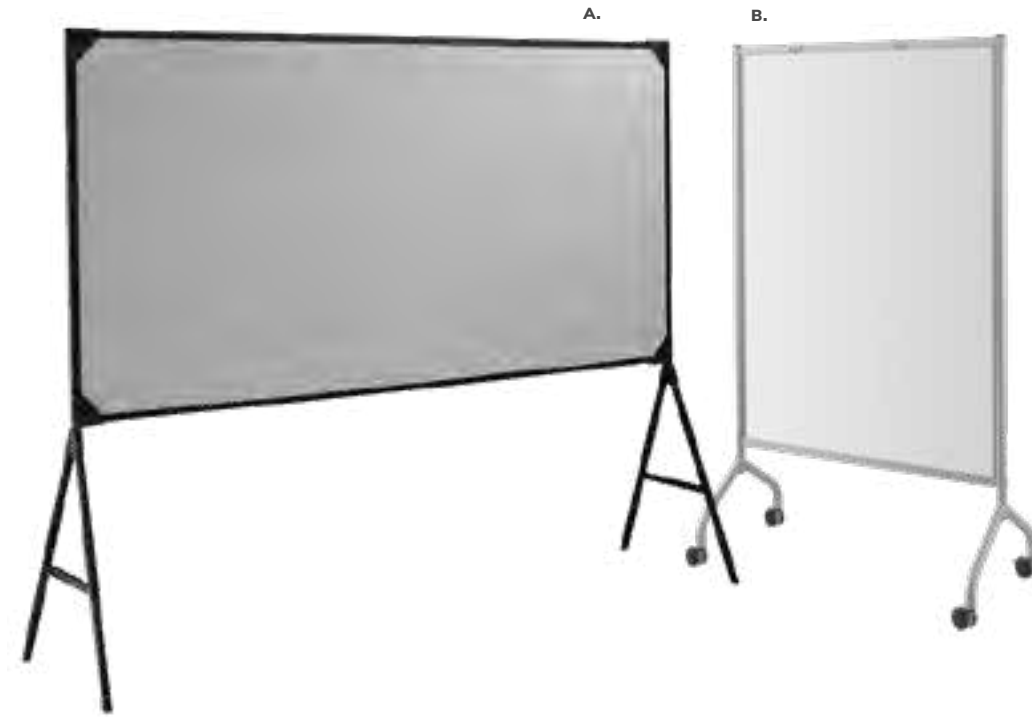

A) 10201484
Floor Standing Bulletin Board
(white laminate, black)
48"W X 96"L X 78"H

B) 84050
Mobile White Board
(white laminate, white)
48"L 24"D 30"H



C) 220110
Chrome Bag Rack
(3" at center)
1"W X 41"H X 26"W

D) 220109
Chrome Coat Tree
(21"w at the base)
8 1/4"W X 69 1/2"H

E) 220134
Brushed Aluminum Easel
(open 5 1/4"W X 64 1/4"H)
26"W X 62"H

F) 220106
Corrugated Wastebasket
(black)

Strategic planning with health & safety in mind

Health & Safety are the top priorities as we consider new designs and ways to connect. When those are clearly emphasized on the show floor, attendees will feel more confident re-engaging.

Together, let's imagine what this new experience will look like - based on both what is possible and realistic. Some recommendations may be new to you. Some, not. To get you started, our top five recommendations include

In all cases, we've put considerable thought into them.

[Click to learn more detailed, interactive, printable checklist.](#)

Freeman® top five health & safety Recommendations include:

1. Strategize your audience approach
2. Re-imagine your booth design.
3. Evaluate a hybrid booth approach
4. Create safe networking opportunities during the show
5. Stay connected to your audience post-show

[Learn More](#)

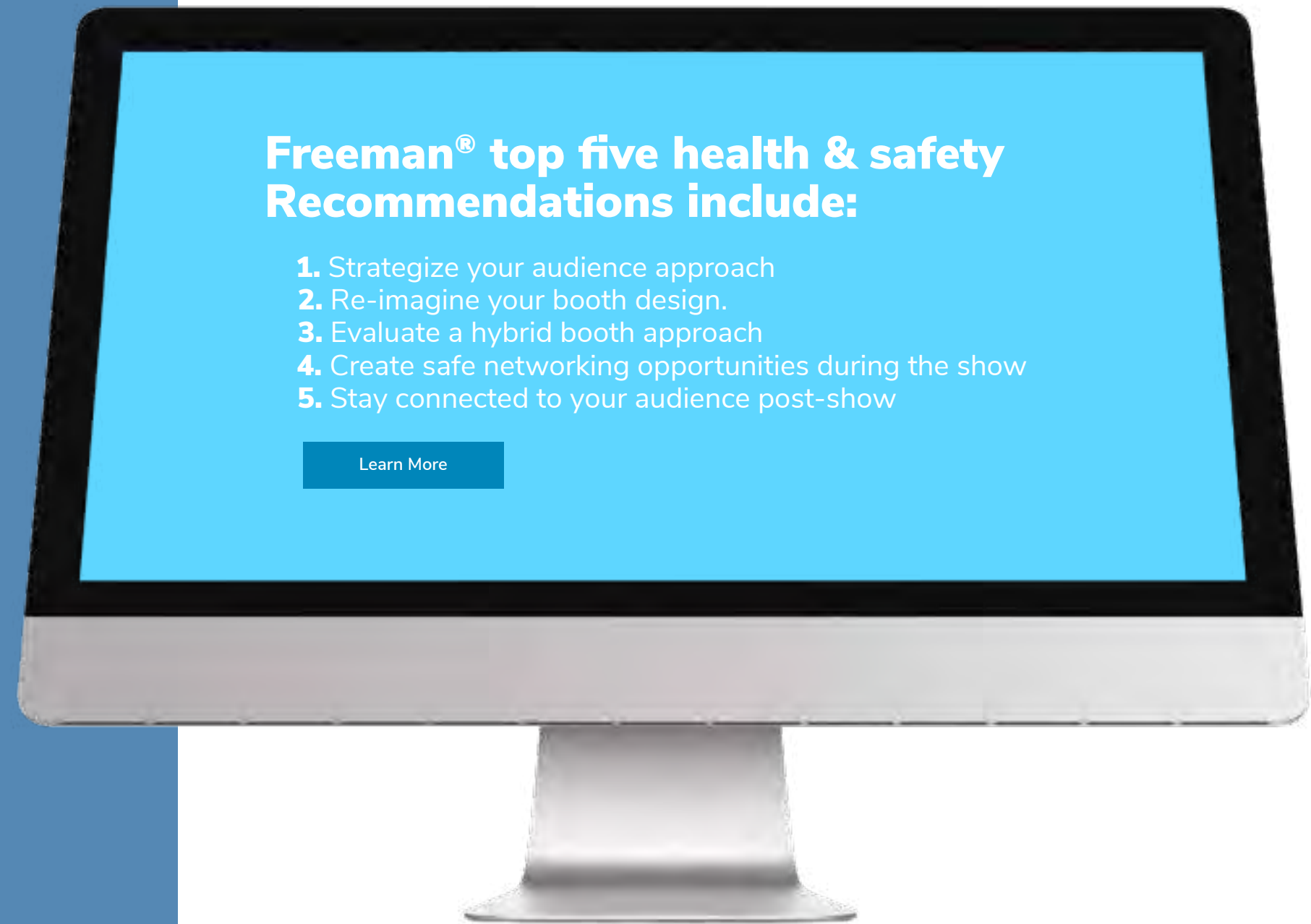

Health & Safety

Safety Dividers

Freeman, offers a complete collection of uniquely designed and safe selling environments that are clean, comfortable, and give your clients peace of mind.

Personalize here

85051 Freestanding Divider
(silver, clear) 39"L 9"D 72"H

Also available in opaque and personalization available.

- 85052 Divider Single Sided Graphic
- 85053 Divider Single-Sided Graphic
- 85090 Divider Double-Sided Graphic



85064 Flag Pole Divider
(silver, clear) 34"L 11"W 47-74"H

Also available in opaque and personalization available.



85055 Freestanding Wall Plus
(silver, clear) 40"L 9"D 72"H

Also available in opaque and personalization available.

- 85056 Panel Single-Sided Graphic
- 85057 Panel Single-Sided Graphic
- 85058 Panel Double-Sided Graphic

85054 Freestanding Corner
(silver, clear) 39"L 39"D 72"H

Also available in opaque and personalization available.



85091 Freestanding White Board
(silver, clear) 40"L 9"D 72"H

Also available in opaque and personalization available.



A) Atomic Round Tables
(glass, chrome)
8201225 42" RND 30"H
8201224 36" RND 30"H

B) 810944 Pro Executive Mid Back Chair
(black vinyl)
24"L 22"D 40"H
Adjustable height

Please Note:

Safety dividers also available in opaque finish. Graphics and branding options also available.

View those options [here](#) and learn more about our SafeConnect Promise on [Freeman.com](#)

Health & Safety

Greenery and Dividers

Keep it Green. Life-like greenery is an easy yet sophisticated way to bridge the distance between seats for a warmer, organic environment.

20'x20' Midtown, Greenery Booth

- Midtown Bar | pg 46
- Dividers | pg 59
- Accent Chair | pg 16
- Bar Tables | pg 7
- Barstools | pg 33
- Greenery | pg 48



85030
7' Boxwood Hedge
36.5"L 12"D 84"H

85035
4' Boxwood Hedge
46"L 9"D 47"H



85050 Clear Divider Bar Counter
(silver, clear) 48-70"L 12"W 31.5"H

Also available in opaque and personalization available.

- 85080 Divider with Header Graphic
- 85083 Divider with Front Panel Graphic
- 85081 Divider with Side Panel Graphic
- 85082 Divider with Header and Side Panel Graphic
- 85084 Divider with Front and Side Graphics



Personalize here



A.

B.

C.

Miramar Dividers
(molded plastic)
A) 85043 (white)
Also available in the following colors.
See page 47.
85043 (harvest yellow)
85042 (burgundy)
85041 (gray)
Vertical: 63"L 23"D 83"H
Horizontal: 83"L 23"D 63"H

B) 8201233
Hydraulic Cafe Table
(orange top, chrome)
30" RND 29"H

C) 810861
Laguna Chair
(maple, chrome)
18"L 19"D 34"H

Please Note:

Safety dividers also available in opaque finish. Graphics and branding options also available.

View those options [Here](#) and learn more about our SafeConnect Promise on [Freeman.com](#)

Health & Safety

Stanchions & Booth Design

Stanchions & Booth Design

Design unique and safe selling environments using stanchions. Create stylish spaces that are comfortable and give your clients peace of mind.



**10'x10' - Beverly
Demonstration Booth**

Greenery | pg 48
Safety Decals | pg 63
Bar Tables | pg 33
Barstools | pg 33
Side Tables | pg 29
Ottomans | pg 24



10'x10' - Atherton Conversation Booth

Greenery | pg 48
Accent Chairs | pg 16
Side Tables | pg 29



**220121
Chrome Stanchion
w/ 8' Retractable Belt**
(black, belt) 42"H



**10'x20' - Wireless Charging
Engagement Booth**

Bar Tables | pg 32
Barstools | pg 33
Charging Tables | pg 11
Ottomans | pg 22

Health & Safety

Safety & Directional Signage

Please reach out to your Freeman contact to discuss suggested use and options. For additional questions please email healthandsafety@freeman.com Layout will include YOUR logo and basic background color.



220118
Chrome Sign Holder
(sign holds) 22"W X 28"H

10'x10' - Atherton Conversation Booth

Greenery | pg 48
Accent Chairs | pg 16
Side Tables | pg 29



Safety & Directional Signage

Design your next booth with Freeman safety signage. Choose from select signage or customize with your brand to complete any size space.



A) Masks Required Sign
20303001 22"W X 28"H
20303002 8.5" W X 11"H

B) Temperature Check Station Sign
20303003 22"W X 28"H
20303004 8.5"W X 11"H

C) If You Are Experiencing Symptoms Sign
20303005 22"W X 28"H
20303006 8.5"W X 11"H

D) Practice Social Distancing Sign
20303007 22"W X 28"H
20303008 8.5"W X 11"H

E) Wash Your Hands Sign
20303009 22"W X 28"H
20303010 8.5"W X 11"H

F) 6' Apart Please Sign
20303011 22"W X 28"H
20303012 8.5"W X 11"H

G) Enter Here Sign
20303013 22"W X 28"H
20303014 8.5"W X 11"H

H) Exit Here Sign
20303015 22"W X 28"H
20303016 8.5"W X 11"H

I) Stand Here Floor Decal
20303017 12"W X 12"H

J) Directional Arrow Floor Decal
20303018 18"W X 24"H

Health & Safety

Sanitization Product & Services

Hand Sanitizing Stations

Using hand sanitizer reduces microbial counts and kills many harmful germs that could compromise the health of attendees with the COVID-19 and other viruses. Hand sanitizing stations provide convenient access to hand sanitizer after interactions where they happen.



1510103 Clear Barrier
(plexi, clear) 31.5"W x 36"H

Also available in opaque and personalization available.

1510100 Clear Barrier with graphic

[Personalize here](#)

Please Note:

Safety dividers also available in opaque finish. Graphics and branding options also available. View those options [here](#) and learn more about our SafeConnect Promise on [Freeman.com](#)

FREEMAN

(888) 508-5054 Fax: (469) 621-5608
 ExhibitorSupport@freeman.com

**ONLINE PRICE
 DISCOUNT PRICE
 DEADLINE DATE
 NOVEMBER 09, 2021**

NAME OF SHOW: **DBC PRI-MED EAST / DECEMBER 9 - 11, 2021**

COMPANY NAME: _____ BOOTH #: _____

CONTACT NAME : _____ PHONE #: _____

E-MAIL ADDRESS : _____

Take advantage of the Online price by ordering at www.freeman.com/store by the deadline date.

Qty	Part #	Description	Online Price	Discount Price	Standard Price	Total
SOFT SEATING						
Naples Group - Black Vinyl						
_____	810119	Chair.....	541.75	595.95	758.45	_____
_____	830120	Loveseat.....	728.75	801.65	1,020.25	_____
_____	830119	Sofa.....	808.50	889.35	1,131.90	_____
Munich Group - Gray Fabric						
_____	810151	Armless Chair.....	577.50	635.25	808.50	_____
Baja Group - White Vinyl						
_____	81050	Chair.....	660.00	726.00	924.00	_____
_____	83020	Loveseat.....	701.25	771.40	981.75	_____
_____	83019	Sofa.....	921.25	1,013.40	1,289.75	_____
Valencia - Velvet						
_____	810180	Chair - Spice Orange.....	354.75	390.25	496.65	_____
_____	83045	Sofa - Coffee Brown.....	533.50	586.85	746.90	_____
Key Largo Group - Black Fabric						
_____	830950	Loveseat.....	563.75	620.15	789.25	_____
_____	830951	Sofa.....	627.00	689.70	877.80	_____
_____	810950	Chair.....	445.50	490.05	623.70	_____
Allegro Group - Blue Fabric						
_____	81019	Chair.....	550.00	605.00	770.00	_____
_____	83015	Sofa.....	874.50	961.95	1,224.30	_____
Fairfax Group - White Vinyl						
_____	810949	Chair.....	376.75	414.45	527.45	_____
_____	830949	Sofa.....	599.50	659.45	839.30	_____
Palm Beach - White Vinyl						
_____	83040	Sofa.....	706.75	777.45	989.45	_____
Sterling Group - Gray Fabric						
_____	81037	Chair.....	979.00	1,076.90	1,370.60	_____
_____	8309	Sofa.....	1,460.25	1,606.30	2,044.35	_____

CASUAL SEATING						
Ottomans						
_____	815122	Endless Square - White Vinyl.....	346.50	381.15	485.10	_____
_____	815123	Endless Square - Black Vinyl.....	346.50	381.15	485.10	_____
_____	815953	Endless Curve - White Vinyl.....	464.75	511.25	650.65	_____
_____	815952	Endless Curve - Black Vinyl.....	464.75	511.25	650.65	_____
_____	81518	Vibe Cube - Blue Vinyl.....	156.75	172.45	219.45	_____
_____	81519	Vibe Cube - Red Vinyl.....	156.75	172.45	219.45	_____
_____	81525	Vibe Cube - Orange Vinyl.....	156.75	172.45	219.45	_____
_____	81517	Vibe Cube - Yellow Vinyl.....	156.75	172.45	219.45	_____
_____	81530	Vibe Cube - Black Vinyl.....	137.50	151.25	192.50	_____
_____	81531	Vibe Cube - White Vinyl.....	137.50	151.25	192.50	_____
_____	81532	Vibe Cube - Steel Blue Vinyl.....	156.75	172.45	219.45	_____

NAME OF SHOW: **DBC PRI-MED EAST / DECEMBER 9 - 11, 2021**

COMPANY NAME:

BOOTH #:

CONTACT NAME :

PHONE #:

E-MAIL ADDRESS :

Take advantage of the Online price by ordering at www.freeman.com/store by the deadline date.

Qty	Part #	Description	Online Price	Discount Price	Standard Price	Total
Ottomans (continued)						
_____	81533	Vibe Cube - Silver Vinyl.....	156.75	172.45	219.45	_____
_____	81534	Vibe Cube - Purple Vinyl.....	156.75	172.45	219.45	_____
_____	81535	Vibe Cube -Citrus Green Vinyl.....	156.75	172.45	219.45	_____
_____	81536	Vibe Cube - Taupe Vinyl.....	156.75	172.45	219.45	_____
_____	81537	Vibe Cube - Spice Orange Vinyl.....	156.75	172.45	219.45	_____
_____	81538	Vibe Cube - Desert Rose Vinyl.....	156.75	172.45	219.45	_____
_____	815151	Marche Swivel - Gray Fabric.....	244.75	269.25	342.65	_____
_____	815154	Marche Swivel - Red Fabric.....	244.75	269.25	342.65	_____
_____	815159	Marche Swivel - Blue Fabric.....	244.75	269.25	342.65	_____
_____	815152	Marche Swivel - Linen Fabric.....	244.75	269.25	342.65	_____
_____	815157	Marche Swivel - Meadow Green Fabric.....	244.75	269.25	342.65	_____
_____	815158	Marche Swivel - Pear Yellow Fabric.....	244.75	269.25	342.65	_____
_____	815156	Marche Swivel - Plum Fabric.....	244.75	269.25	342.65	_____
_____	815153	Marche Swivel - Raspberry Fabric.....	244.75	269.25	342.65	_____
_____	815155	Marche Swivel - Rose Quartz Fabric.....	244.75	269.25	342.65	_____
_____	815150	Marche Swivel - White Vinyl.....	244.75	269.25	342.65	_____
_____	815160	Marche Swivel - Orange Fabric.....	244.75	269.25	342.65	_____
_____	81540	Marche Swivel - Forest Green Vinyl.....	244.75	269.25	342.65	_____
_____	81541	Marche Swivel - Teal Velvet.....	244.75	269.25	342.65	_____
_____	81542	Marche Swivel - Distressed Brown Vinyl.....	244.75	269.25	342.65	_____
_____	81543	Marche Swivel - Black Vinyl.....	244.75	269.25	342.65	_____
_____	81539	Marche Swivel - Ivory Faux Sheep Fur.....	244.75	269.25	342.65	_____
Beverly Bench Ottomans						
_____	81550	Black Vinyl.....	492.25	541.50	689.15	_____
_____	81551	Brown Fabric.....	492.25	541.50	689.15	_____
_____	81552	Gray Fabric.....	492.25	541.50	689.15	_____
_____	81553	Linen Fabric.....	492.25	541.50	689.15	_____
_____	81554	Ocean Blue Fabric.....	492.25	541.50	689.15	_____
_____	81555	Red Fabric.....	492.25	541.50	689.15	_____
_____	81556	White Vinyl.....	492.25	541.50	689.15	_____
Beverly Small Bench Ottomans						
_____	81560	Black Vinyl.....	294.25	323.70	411.95	_____
_____	81561	Blue Fabric.....	294.25	323.70	411.95	_____
_____	81562	Brown Fabric.....	294.25	323.70	411.95	_____
_____	81563	Green Fabric.....	294.25	323.70	411.95	_____
_____	81565	Linen Fabric.....	294.25	323.70	411.95	_____
_____	81568	Red Fabric.....	294.25	323.70	411.95	_____
_____	81569	White Vinyl.....	294.25	323.70	411.95	_____
_____	81566	Lavender Fabric.....	294.25	323.70	411.95	_____
_____	81567	Orange Fabric.....	294.25	323.70	411.95	_____
_____	81564	Gray Fabric.....	294.25	323.70	411.95	_____
_____	81570	Yellow Fabric.....	294.25	323.70	411.95	_____
Accent Chairs						
_____	71089	Black Diamond Side Chair.....	152.00	167.20	212.80	_____
_____	71090	Black Diamond Arm Chair.....	202.00	222.20	282.80	_____
_____	810861	Laguna Chair - Maple/Chrome.....	151.25	166.40	211.75	_____
_____	210108	Limerick® Chair by Herman Miller.....	118.45	130.30	165.85	_____

NAME OF SHOW: **DBC PRI-MED EAST / DECEMBER 9 - 11, 2021**

COMPANY NAME: _____ BOOTH #: _____

CONTACT NAME : _____ PHONE #: _____

E-MAIL ADDRESS : _____

Take advantage of the Online price by ordering at www.freeman.com/store by the deadline date.

Qty	Part #	Description	Online Price	Discount Price	Standard Price	Total
Accent Chairs (continued)						
	810816	Madrid Chair - White Vinyl/Chrome.....	827.75	910.55	1,158.85	
	810948	Meeting Chair - White Vinyl.....	261.25	287.40	365.75	
	810164	Marina Chair - White Vinyl.....	162.25	178.50	227.15	
	810160	Marina Chair - Black Vinyl.....	162.25	178.50	227.15	
	810161	Marina Chair - Brown Fabric.....	162.25	178.50	227.15	
	810162	Marina Chair - Ocean Blue Fabric.....	162.25	178.50	227.15	
	810163	Marina Chair - Red Fabric.....	162.25	178.50	227.15	
	810131	Malba Chair - Gray Molded Plastic.....	110.00	121.00	154.00	
	810130	Malba Chair - Green Molded Plastic.....	107.25	118.00	150.15	
	810846	Christopher Chair - White Vinyl/Chrome.....	134.75	148.25	188.65	
	810851	Zenith Chair - White/Chrome.....	170.50	187.55	238.70	
	810841	Rustique Chair - Gunmetal.....	107.25	118.00	150.15	
	810837	Razor Armless Chair - White High Density Plastic.....	63.25	69.60	88.55	
	810875	Swanson Swivel Chair - White Vinyl.....	379.50	417.45	531.30	
	81083	Blade Chair - Sky Blue.....	88.00	96.80	123.20	
	81082	Blade Chair - Red.....	88.00	96.80	123.20	
	81093	Lucent Chair - Frosted Acrylic.....	228.25	251.10	319.55	
	810145	Wentworth Chair - Brown Vinyl.....	371.25	408.40	519.75	
	81024	Atherton Chair - Brown Leather.....	569.25	626.20	796.95	
	81034	Bowery Chair - Yellow Fabric.....	533.50	586.85	746.90	
	81035	Century Chair - Gray Velvet.....	599.50	659.45	839.30	
	81036	Lena Chair - Green Leather.....	481.25	529.40	673.75	
	81031	Montreal Chair - Blue Fabric.....	684.75	753.25	958.65	
	81032	Pasadena Chair - White Plastic.....	385.00	423.50	539.00	
	81038	Tech Chair - Gray Vinyl.....	462.00	508.20	646.80	
	81039	Tech Tablet Chair - Gray Vinyl.....	475.75	523.35	666.05	
Executive Seating						
	71045	Gray Gaslift Chair Without Arms.....	310.00	341.00	434.00	
	810874	La Brea Swivel Chair - Charcoal Gray Fabric.....	346.50	381.15	485.10	
	810175	Genesis Chair - Black.....	1,839.75	2,023.75	2,575.65	
	810844	Pro Executive High Back Chair - White Vinyl.....	302.50	332.75	423.50	
	810946	Pro Executive High Back Chair - Black Vinyl.....	302.50	332.75	423.50	
	810945	Pro Executive Mid Back Chair - White Vinyl.....	385.00	423.50	539.00	
	810944	Pro Executive Mid Back Chair - Black Vinyl.....	385.00	423.50	539.00	
	810947	Pro Executive Guest Chair - Black Vinyl.....	398.75	438.65	558.25	
	810170	Cupertino Mid Back Chair - Black Vinyl.....	283.25	311.60	396.55	
Barstools						
	71088	Black Diamond Stool.....	252.00	277.20	352.80	
	71047	Gray Gaslift Stool without Arms.....	390.00	429.00	546.00	
	810860	Laguna Barstool - Maple/Chrome.....	189.75	208.75	265.65	
	210109	Limerick® Stool by Herman Miller.....	164.80	181.30	230.70	
	810872	Lift Barstool - Gray Vinyl/Chrome.....	178.75	196.65	250.25	
	810873	Lift Barstool - Red Vinyl/Chrome.....	178.75	196.65	250.25	
	810871	Lift Barstool - Black Vinyl/Chrome.....	178.75	196.65	250.25	
	810870	Lift Barstool - White Vinyl/Chrome.....	178.75	196.65	250.25	
	810103	Banana Barstool - White Vinyl/Chrome.....	211.75	232.95	296.45	

NAME OF SHOW: **DBC PRI-MED EAST / DECEMBER 9 - 11, 2021**

COMPANY NAME: _____ BOOTH #: _____

CONTACT NAME : _____ PHONE #: _____

E-MAIL ADDRESS : _____

Take advantage of the Online price by ordering at www.freeman.com/store by the deadline date.

Qty	Part #	Description	Online Price	Discount Price	Standard Price	Total
Barstools (continued)						
_____	810104	Banana Barstool - Black Vinyl/Chrome.....	211.75	232.95	296.45	_____
_____	810850	Zenith Barstool - White/Chrome.....	170.50	187.55	238.70	_____
_____	810840	Zoey Barstool - White Vinyl/Chrome.....	330.00	363.00	462.00	_____
_____	810848	Christopher Barstool - White Vinyl/Chrome.....	231.00	254.10	323.40	_____
_____	810202	Shark Swivel Barstool - White Plastic/Chrome.....	365.75	402.35	512.05	_____
_____	810839	Rustique Barstool - Gunmetal.....	118.25	130.10	165.55	_____
_____	81080	Blade Barstool - Red.....	178.75	196.65	250.25	_____
_____	81081	Blade Barstool - Sky Blue.....	178.75	196.65	250.25	_____
_____	81092	Lucent Barstool - Frosted Acrylic.....	242.00	266.20	338.80	_____
_____	810135	Task Stool - Black Fabric.....	195.25	214.80	273.35	_____
_____	81026	Marina Barstool - Ocean Blue.....	321.75	353.95	450.45	_____
_____	81027	Marina Barstool - Black Vinyl.....	321.75	353.95	450.45	_____
_____	81028	Marina Barstool - Brown Fabric.....	321.75	353.95	450.45	_____
_____	81029	Marina Barstool - Red Fabric.....	321.75	353.95	450.45	_____
_____	81030	Marina Barstool - White Vinyl.....	321.75	353.95	450.45	_____

Draped Tables & Counters

Draped Tables - Tables are 24" wide <input type="checkbox"/> Black <input type="checkbox"/> Blue <input type="checkbox"/> White <input type="checkbox"/> Gray <input type="checkbox"/> Red
--

_____	124430	Draped Table 4'L x 30"H.....	206.00	226.60	288.40	_____
_____	124630	Draped Table 6'L x 30"H.....	247.20	271.90	346.10	_____
_____	124830	Draped Table 8'L x 30"H.....	288.40	317.25	403.75	_____
_____	12404630	4th Side Drape 6'L x 30"H.....	51.50	56.65	72.10	_____
_____	12404830	4th Side Drape 8'L x 30"H.....	51.50	56.65	72.10	_____
_____	124442	Draped Counter 4'L x 42"H.....	241.05	265.15	337.45	_____
_____	124642	Draped Counter 6'L x 42"H.....	294.60	324.05	412.45	_____
_____	124842	Draped Counter 8'L x 42"H.....	348.15	382.95	487.40	_____
_____	12404642	4th Side Drape 6'L x 42"H.....	56.65	62.30	79.30	_____
_____	12404842	4th Side Drape 8'L x 42"H.....	56.65	62.30	79.30	_____

Undraped Tables & Counters

_____	125430	Undraped Table 4'L x 30"H.....	82.40	90.65	115.35	_____
_____	125630	Undraped Table 6'L x 30"H.....	123.60	135.95	173.05	_____
_____	125830	Undraped Table 8'L x 30"H.....	164.80	181.30	230.70	_____
_____	125442	Undraped Counter 4'L x 42"H.....	107.15	117.85	150.00	_____
_____	125642	Undraped Counter 6'L x 42"H.....	160.70	176.75	225.00	_____
_____	125842	Undraped Counter 8'L x 42"H.....	214.25	235.70	299.95	_____

Table Top Risers - Risers are 8" wide

_____	1504100	Black 4'L x 7"H Corrugated Riser.....	30.15	33.15	42.20	_____
_____	1504101	White 4'L x 7"H Corrugated Riser.....	30.15	33.15	42.20	_____
_____	1506100	Black 6'L x 7"H Corrugated Riser.....	35.30	38.85	49.40	_____
_____	1506101	White 6'L x 7"H Corrugated Riser.....	35.30	38.85	49.40	_____
_____	1508100	Black 8'L x 7"H Corrugated Riser.....	40.70	44.75	57.00	_____
_____	1508101	White 8'L x 7"H Corrugated Riser.....	40.70	44.75	57.00	_____

furnishings

NAME OF SHOW: **DBC PRI-MED EAST / DECEMBER 9 - 11, 2021**

COMPANY NAME: _____ BOOTH #: _____

CONTACT NAME : _____ PHONE #: _____

E-MAIL ADDRESS : _____

Take advantage of the Online price by ordering at www.freeman.com/store by the deadline date.

Qty	Part #	Description	Online Price	Discount Price	Standard Price	Total
Table Top Risers - Risers are 8" wide (continued)						
_____	1504200	Black 4'L x 14"H Corrugated Riser.....	46.10	50.70	64.55	_____
_____	1504201	White 4'L x 14"H Corrugated Riser.....	46.10	50.70	64.55	_____
_____	1506200	Black 6'L x 14"H Corrugated Riser.....	56.40	62.05	78.95	_____
_____	1506201	White 6'L x 14"H Corrugated Riser.....	56.40	62.05	78.95	_____
_____	1508200	Black 8'L x 14"H Corrugated Riser.....	66.70	73.35	93.40	_____
_____	1508201	White 8'L x 14"H Corrugated Riser.....	66.70	73.35	93.40	_____
Pedestal Tables - Soho Series						
_____	72069	Black Top Cafe Table - 30"H x 24"W.....	385.00	423.50	539.00	_____
_____	72067	Black Top Cafe Table - 30"H x 36"W.....	385.00	423.50	539.00	_____
_____	72066	Black Top Mini Table - 18"H x 18"W.....	285.00	313.50	399.00	_____
_____	72070	Black Top Bistro Table - 42"H x 24"W.....	385.00	423.50	539.00	_____
_____	72068	Black Top Bistro Table - 42"H x 36"W.....	385.00	423.50	539.00	_____
Pedestal Tables - Chelsea Series						
_____	72063	Butcher Block Top Cafe Table - 30"H x 30"W.....	225.00	247.50	315.00	_____
_____	72064	Butcher Block Top Cafe Table - 30"H x 36"W.....	225.00	247.50	315.00	_____
_____	720163	Butcher Block Top Bistro Table - 42"H x 30"W.....	225.00	247.50	315.00	_____
_____	720164	Butcher Block Top Bistro Table - 42"H x 36"W.....	225.00	247.50	315.00	_____
Pedestal Tables						
_____	8201208	Hydraulic Base Cafe Table - Maple.....	382.25	420.50	535.15	_____
_____	8201207	Hydraulic Base Bar Table - Maple.....	398.75	438.65	558.25	_____
_____	8201209	Hydraulic Base Cafe Table - Graphite.....	426.25	468.90	596.75	_____
_____	8201211	Hydraulic Base Bar Table - Graphite.....	437.25	481.00	612.15	_____
_____	8201206	Hydraulic Base Cafe Table - Maple.....	434.50	477.95	608.30	_____
_____	8201205	Hydraulic Base Bar Table - Maple.....	429.00	471.90	600.60	_____
_____	820126	Hydraulic Base Cafe Table - White Laminate.....	434.50	477.95	608.30	_____
_____	820125	Hydraulic Base Bar Table - White Laminate.....	453.75	499.15	635.25	_____
_____	820241	Madison Hydraulic Base Cafe Table - Gray Acajou.	341.00	375.10	477.40	_____
_____	820240	Madison Hydraulic Base Bar Table - Gray Acajou...	341.00	375.10	477.40	_____
_____	820265	Madison Cafe Table - Gray Acajou.....	269.50	296.45	377.30	_____
_____	820264	Madison Bar Table - Gray Acajou.....	294.25	323.70	411.95	_____
_____	8201220	30" Cafe Table Black Base - White Laminate.....	286.00	314.60	400.40	_____
_____	8201221	30" Bar Table Black Base - White Laminate.....	308.00	338.80	431.20	_____
_____	8201222	30" Bar Table Chrome Base - White Laminate.....	440.00	484.00	616.00	_____
_____	8201223	30" Cafe Table Chrome Base - White Laminate.....	440.00	484.00	616.00	_____
_____	820920	30" Bar Table Chrome Hydraulic Base - Red.....	341.00	375.10	477.40	_____
_____	820921	30" Cafe Table Chrome Hydraulic Base - Red.....	341.00	375.10	477.40	_____
_____	820922	30" Bar Table Chrome Hydraulic Base - Graphite....	341.00	375.10	477.40	_____
_____	820923	30" Cafe Table Chrome Hydraulic Base - Graphite....	341.00	375.10	477.40	_____
_____	820930	30" Bar Table w/ Hydraulic Base - Blue.....	332.75	366.05	465.85	_____
_____	820931	30" Bar Table w/ Black Base - Blue.....	264.00	290.40	369.60	_____
_____	820932	30" Bar Table w/ Hydraulic Base - Wood.....	407.00	447.70	569.80	_____
_____	820933	30" Bar Table w/ Black Base - Wood.....	272.25	299.50	381.15	_____
_____	820940	30" Cafe Table w/ Hydraulic Base - Blue.....	332.75	366.05	465.85	_____
_____	820941	30" Cafe Table w/ Black Base - Blue.....	203.50	223.85	284.90	_____
_____	820942	30" Cafe Table w/ Hydraulic Base - Wood.....	407.00	447.70	569.80	_____

COMPANY NAME: _____ BOOTH #: _____

CONTACT NAME : _____ PHONE #: _____

E-MAIL ADDRESS : _____

Take advantage of the Online price by ordering at www.freeman.com/store by the deadline date.

Qty	Part #	Description	Online Price	Discount Price	Standard Price	Total
Pedestal Tables (continued)						
	820943	30" Cafe Table w/ Black Base - Wood.....	258.50	284.35	361.90	
	820910	30" Bar Table w/ Hydraulic Base - Gunmetal.....	440.00	484.00	616.00	
	820911	30" Bar Table w/ Hydraulic Base - Black.....	440.00	484.00	616.00	
	820912	30" Bar Table w/ Hydraulic Base - Green.....	440.00	484.00	616.00	
	820913	30" Bar Table w/ Hydraulic Base - Orange.....	440.00	484.00	616.00	
	820914	30" Bar Table w/ Hydraulic Base - Yellow.....	440.00	484.00	616.00	
	820915	30" Bar Table w/ Black Base - Gunmetal.....	308.00	338.80	431.20	
	820916	30" Bar Table w/ Black Base - Black.....	308.00	338.80	431.20	
	820917	30" Bar Table w/ Black Base - Green.....	308.00	338.80	431.20	
	820918	30" Bar Table w/ Black Base - Orange.....	308.00	338.80	431.20	
	820919	30" Bar Table w/ Black Base - Yellow.....	308.00	338.80	431.20	
	8201230	30" Cafe Table w/ Hydraulic Base - Gunmetal.....	440.00	484.00	616.00	
	8201231	30" Cafe Table w/ Hydraulic Base - Black.....	440.00	484.00	616.00	
	8201232	30" Cafe Table w/ Hydraulic Base - Green.....	440.00	484.00	616.00	
	8201233	30" Cafe Table w/ Hydraulic Base - Orange.....	440.00	484.00	616.00	
	8201234	30" Cafe Table w/ Hydraulic Base - Yellow.....	440.00	484.00	616.00	
	8201235	30" Cafe Table w/ Black Base - Gunmetal.....	286.00	314.60	400.40	
	8201236	30" Cafe Table w/ Black Base - Black.....	286.00	314.60	400.40	
	8201237	30" Cafe Table w/ Back Base - Green.....	286.00	314.60	400.40	
	8201238	30" Cafe Table w/ Black Base - Orange.....	286.00	314.60	400.40	
	8201239	30" Cafe Table w/ Black Base - Yellow.....	286.00	314.60	400.40	
	8201240	36" Bar Table w/ Hydraulic Base - Black.....	453.75	499.15	635.25	
	8201241	36" Bar Table w// Black Base - Black.....	310.75	341.85	435.05	
	8201242	36" Cafe Table w/ Hydraulic Base - Black.....	434.50	477.95	608.30	
	8201243	36" Cafe Table w// Black Base - Black.....	335.50	369.05	469.70	
Accent Tables						
	82015	Silverado End Table - Tempered Glass/Painted Steel.....	283.25	311.60	396.55	
	82014	Silverado Cocktail Table - Tempered Glass/Painted Steel.....	302.50	332.75	423.50	
	820252	Alondra End Table - Glass/Chrome.....	247.50	272.25	346.50	
	820250	Alondra Cocktail Table - Glass/Chrome.....	346.50	381.15	485.10	
	820253	Alondra End Table - Wood/Chrome.....	247.50	272.25	346.50	
	820251	Alondra Cocktail Table - Wood/Chrome.....	346.50	381.15	485.10	
	8201224	Atomic 36" Round Table - Glass/Chrome.....	385.00	423.50	539.00	
	8201225	Atomic 42" Round Table - Glass/Chrome.....	385.00	423.50	539.00	
	82028	Geo End Table - Wood/Black Steel.....	294.25	323.70	411.95	
	82027	Geo Cocktail Table - Wood/Black Steel.....	299.75	329.75	419.65	
	82035	Geo End Table - Glass/Chrome.....	217.25	239.00	304.15	
	82034	Geo Cocktail Table - Glass/Chrome.....	203.50	223.85	284.90	
	82054	Sydney End Table - Black Laminate/Brushed Steel..	264.00	290.40	369.60	
	82055	Sydney End Table - White Laminate/Brushed Steel..	264.00	290.40	369.60	
	82052	Sydney Cocktail Table - Black Laminate/Brushed Steel.....	319.00	350.90	446.60	
	82053	Sydney Cocktail Table - White Laminate/Brushed Steel.....	319.00	350.90	446.60	
	82079	Sydney End Table - Blue Laminate/Brushed Steel.....	258.50	284.35	361.90	
	82080	Sydney End Table - Wood Laminate/Brushed Steel..	258.50	284.35	361.90	
	82077	Sydney Cocktail Table - Blue Laminate/Brushed Steel.....	313.50	344.85	438.90	

NAME OF SHOW: **DBC PRI-MED EAST / DECEMBER 9 - 11, 2021**

COMPANY NAME: _____ BOOTH #: _____

CONTACT NAME : _____ PHONE #: _____

E-MAIL ADDRESS : _____

Take advantage of the Online price by ordering at www.freeman.com/store by the deadline date.

Qty	Part #	Description	Online Price	Discount Price	Standard Price	Total
Accent Tables (continued)						
	82078	Sydney Cocktail Table - Wood Laminate/Brushed Steel.....	313.50	344.85	438.90	
	82075	Regis End Table - Brushed Metal.....	261.25	287.40	365.75	
	82074	Regis Bench Table - Brushed Metal.....	368.50	405.35	515.90	
	820844	Aura Round Table - White Metal.....	143.00	157.30	200.20	
	82043	Geo Square-Round Table - Glass/Black Steel.....	349.25	384.20	488.95	
	82044	Geo Square-Round Table - Glass/Chrome.....	349.25	384.20	488.95	
	8201226	Rustique Square Metal Bar Table - Gray.....	338.25	372.10	473.55	
	820130	Mesa Cocktail Table - Black/Bronze.....	319.00	350.90	446.60	
	820131	Mesa Cocktail Table - Glass/Bronze.....	319.00	350.90	446.60	
	820132	Mesa Cocktail Table - Wood/Bronze.....	319.00	350.90	446.60	
	820133	Mesa End Table - Black/Bronze.....	280.50	308.55	392.70	
	820134	Mesa End Table - Glass/Bronze.....	280.50	308.55	392.70	
	820135	Mesa End Table - Wood/Bronze.....	280.50	308.55	392.70	
	820310	Sedona Side Table - Black/Bronze.....	869.00	955.90	1,216.60	
	820311	Sedona Side Table - Wood/Bronze.....	151.25	166.40	211.75	
	820312	Sedona Side Table - White/Bronze.....	151.25	166.40	211.75	
	820320	Taos Side Table - Black/Bronze.....	151.25	166.40	211.75	
	820321	Taos Side Table Wood/Bronze.....	151.25	166.40	211.75	
	820322	Taos Side Table - White/Bronze.....	151.25	166.40	211.75	
Conference Tables						
	82041	Geo Conference Table - Glass/Black Steel.....	434.50	477.95	608.30	
	82051	Geo Conference Table - Glass/Chrome.....	429.00	471.90	600.60	
	820260	Madison Conference Table - Gray Acajou.....	459.25	505.20	642.95	
	820708	42" Round Conference Table - White Laminate.....	453.75	499.15	635.25	
	820261	Madison 5' Conference Table - Gray Acajou.....	558.25	614.10	781.55	
	820262	Madison 8' Conference Table - Gray Acajou.....	1,111.00	1,222.10	1,555.40	
	820263	Madison 10' Conference Table - Gray Acajou.....	1,111.00	1,222.10	1,555.40	
	820951	Ventura Bar Table - Maple w/ Grommets.....	833.25	916.60	1,166.55	
	820952	Ventura Communal Bar Table - Black.....	816.75	898.45	1,143.45	
	820953	Ventura Bar Table - White w/ Grommets.....	833.25	916.60	1,166.55	
	820954	Ventura Communal Bar Table - Maple.....	833.25	916.60	1,166.55	
	820956	Ventura Communal Bar Table - White.....	833.25	916.60	1,166.55	
	820963	Ventura Communal Cafe Table - Maple.....	544.50	598.95	762.30	
	820960	Ventura Cafe Table - Maple w/ Grommets.....	816.75	898.45	1,143.45	
	820961	Ventura Cafe Table - White w/ Grommets.....	816.75	898.45	1,143.45	
	820966	Ventura Communal Cafe Table - White.....	544.50	598.95	762.30	
	820962	Ventura Communal Cafe Table - Black.....	544.50	598.95	762.30	
	8201244	42" Round Conference Table - Black Laminate.....	453.75	499.15	635.25	
	8201	10' Table - Black Laminate.....	984.50	1,082.95	1,378.30	
	8203	5' Table - Black Laminate.....	506.00	556.60	708.40	
	8205	8' Table - Black Laminate.....	742.50	816.75	1,039.50	
Office						
	84075	Madison Desk - Gray Acajou.....	654.50	719.95	916.30	
	84078	Madison Bookcase - Gray Acajou.....	467.50	514.25	654.50	

furnishings

NAME OF SHOW: **DBC PRI-MED EAST / DECEMBER 9 - 11, 2021**

COMPANY NAME: _____ BOOTH #: _____

CONTACT NAME : _____ PHONE #: _____

E-MAIL ADDRESS : _____

Take advantage of the Online price by ordering at www.freeman.com/store by the deadline date.

Qty	Part #	Description	Online Price	Discount Price	Standard Price	Total
Computer Desks/Tables						
	820706	Work Desk - White Laminate.....	390.50	429.55	546.70	
POWERED						
Powered Seating						
	810120	Naples Chair, Powered - Black Vinyl.....	770.00	847.00	1,078.00	
	830122	Naples Loveseat, Powered - Black Vinyl.....	1,036.75	1,140.45	1,451.45	
	830121	Naples Sofa, Powered - Black Vinyl.....	1,190.75	1,309.85	1,667.05	
Powered Tables						
	820950	Ventura Communal Bar Table, Powered - Black.....	1,009.25	1,110.20	1,412.95	
	820955	Ventura Communal Bar Table, Powered - White.....	918.50	1,010.35	1,285.90	
	820964	Ventura Communal Cafe Table, Powered - Black.....	690.25	759.30	966.35	
	820965	Ventura Communal Cafe Table, Powered - White.....	690.25	759.30	966.35	
	84083	Tech Desk w/ 3 Drawer File Cabinet, Powered - Black Metal.....	615.00	676.50	861.00	
	84084	Tech Desk, Powered - Black Metal.....	594.00	653.40	831.60	
	82076	Sydney Cocktail Table, Powered - Black.....	459.25	505.20	642.95	
	82073	Sydney Cocktail Table, Powered - White.....	459.25	505.20	642.95	
	8202	10' Table, Powered - Black Laminate.....	1,232.00	1,355.20	1,724.80	
	8204	5' Table, Powered - Black Laminate.....	638.00	701.80	893.20	
	8206	8' Table, Powered - Black Laminate.....	1,232.00	1,355.20	1,724.80	
Powered Pedestals						
	85060	Powered Locking Pedestal 36" H, Black.....	561.00	617.10	785.40	
	85061	Powered Locking Pedestal 36" H, White.....	561.00	617.10	785.40	
	85062	Powered Locking Pedestal 42" H, Black.....	671.00	738.10	939.40	
	85063	Powered Locking Pedestal 42" H, White.....	671.00	738.10	939.40	
	820710	Wireless Charging Table, Powered.....	547.25	602.00	766.15	
Midtown Counters & Bars						
	850103	Midtown Powered Counter Unlighted - Pewter.....	1,647.25	1,812.00	2,306.15	
	850102	Midtown Powered Counter Lighted w/ Plug-In - Pewter.....	1,922.25	2,114.50	2,691.15	
	850101	Midtown Bar Unlighted - Pewter.....	1,482.25	1,630.50	2,075.15	
	850100	Midtown Bar Lighted w/ Plug-In - Pewter.....	1,757.25	1,933.00	2,460.15	
DISPLAY & ACCESSORIES						
Product Storage						
	84080	3 Door File Cabinet on Castors - Black	206.25	226.90	288.75	
	85020	Posh Shelving w/ Chrome Frame - White.....	613.25	674.60	858.55	
Refrigerator						
	8503001	Refrigerator - White.....	1,787.50	1,966.25	2,502.50	
Lighting						
	850707	Mason Table Lamp - White/Brushed Silver.....	170.50	187.55	238.70	
	850708	Mason Floor Lamp - White/Brushed Silver.....	255.75	281.35	358.05	
Display						
	75030	Display Cube - Black - 12" Small.....	280.00	308.00	392.00	
	75031	Display Cube - Black - 18" Medium.....	280.00	308.00	392.00	
	75032	Display Cube - Black - 24" Large.....	280.00	308.00	392.00	
	72056	Display Counter - Black.....	280.00	308.00	392.00	

NAME OF SHOW: **DBC PRI-MED EAST / DECEMBER 9 - 11, 2021**

COMPANY NAME: _____ BOOTH #: _____

CONTACT NAME : _____ PHONE #: _____

E-MAIL ADDRESS : _____

Take advantage of the Online price by ordering at www.freeman.com/store by the deadline date.

Qty	Part #	Description	Online Price	Discount Price	Standard Price	Total
Boxwood Hedges						
_____	85030	7' Boxwood Hedge.....	568.00	624.80	795.20	_____
_____	85035	4' Boxwood Hedge.....	304.00	334.40	425.60	_____
Accessories						
_____	220121	Chrome Stanchion w/ 8' Retractable Belt.....	105.00	115.50	147.00	_____
_____	220118	Chrome Sign Holder.....	150.00	165.00	210.00	_____
_____	750135	Round Literature Rack.....	245.00	269.50	343.00	_____
_____	750136	Flat Literature Rack.....	220.00	242.00	308.00	_____
_____	220109	Chrome Coat Tree.....	70.00	77.00	98.00	_____
_____	220134	Aluminum Easel.....	60.00	66.00	84.00	_____
_____	220110	Chrome Bag Rack.....	160.00	176.00	224.00	_____
_____	10201484	Floor Standing Bulletin Board.....	332.40	365.65	465.35	_____
_____	220106	Corrugated Wastebasket.....	25.00	27.50	35.00	_____
_____	8502	Village Charging Hub.....	266.75	293.45	373.45	_____
Special Drape						
<input type="checkbox"/> Black <input type="checkbox"/> Blue <input type="checkbox"/> White <input type="checkbox"/> Gray <input type="checkbox"/> Red						
_____	12103	Special Drape 3'H (per ft.).....	10.00	11.00	14.00	_____
_____	12108	Special Drape 8'H (per ft.).....	12.00	13.20	16.80	_____

TOTAL COST		
_____	+	_____ = _____
Sub-Total		6.25% Tax Total Cost

Taxes: Due to varying taxes across counties and cities for various categories, applicable taxes will be applied to your order accordingly based on the jurisdictions of the show city.

FROM THE GROUND UP

Engage your audience from the moment they set foot in your exhibit with custom carpets. Our colorfast carpeting boasts a consistent shade every time and the padding exceeds industry standards, ensuring that you'll be floored by the quality. Custom options can be ordered and include borders, patterns and logo applications in both our classic and prestige carpeting lines.

Sustainability Tip:

 DARKER COLORED CARPETS SUCH AS BLACK AND GRAY AND THE TWO-TONED CARPET ARE MADE OF 20-25% RECYCLED CONTENT. RENTING CARPET FROM FREEMAN MINIMIZES YOUR SHIPPING FOOTPRINT.

- Colorfast carpet technology guarantees a uniform and professional look throughout the life of your exhibit
- Diverse customization options guarantee the fulfillment of your brand standards
- All carpet and padding is manufactured with recycled material
- Rental prices are all-inclusive so there are never hidden charges for material handling or pickup
- Renting carpet from Freeman minimizes your shipping footprint.



Call customer service at the number listed on the Quick Facts. For fast, easy ordering, go to freeman.com

PRESTIGE CARPET

Freeman's prestige carpet combines plush comfort with durable soil and stain resistance, perfect for high-traffic areas. Five popular colors are available in a luxurious 40-ounce weight and all nine designer colors are available in a 28-ounce weight.

Freeman's prestige carpet packages include new 10-foot-wide carpet, delivery, Visqueen covering, installation, carpet tape, carpet removal and all carpet material handling fees. Prestige carpet is one time use. The carpet for your booth will be brand new and recycled at the end of the show. Price includes environmentally friendly disposal of carpet after usage. Foam carpet padding is available for a minimal fee. If you have a large order, please contact us to see if volume discounts may apply.

Custom Options

Prestige carpets can also be customized to fit your exhibit needs with unique logos, patterns and borders. Call the phone number on the Quick Facts for assistance.



*Colors available in both 28 oz. and 40 oz.

 **Sustainability Tip:** Prestige carpet is one time use. The carpet for your booth will be brand new and recycled at the end of the show.

CLASSIC CARPET

Custom Cut

Freeman classic carpet is available in a range of colors and includes delivery, Visqueen covering, installation, carpet tape, carpet removal and all carpet material handling fees. Foam carpet padding is available for a minimal fee. If you have a large order, please contact us to see if volume discounts may apply.

Standard Cut

Our classic carpet comes in a variety of sizes. Prices include delivery, installation, carpet tape, carpet removal and all carpet material handling fees. Foam carpet padding and Visqueen covering are available for a minimal fee.



Actual colors may vary slightly

Sustainability Tip: Freeman Classic carpet is reused a minimum of four times before retired from inventory and recycled. Darker colored carpets such as black and gray, as well as the two-toned carpet are made of 20-25% recycled content.

NAME OF SHOW: **DBC PRI-MED EAST / DECEMBER 9 - 11, 2021**

COMPANY NAME: _____ BOOTH #: _____

CONTACT NAME: _____ PHONE #: _____

E-MAIL ADDRESS: _____

Take advantage of the Online Price by ordering at www.freeman.com/store by the deadline date.

FLOORING

- Orders received after the deadline date or without payment will be charged the Standard Price and are subject to availability.
- Products or colors with limited availability after the discount deadline denoted with an asterisk *
- All utility lines must be installed before carpet installation. Utilities should be ordered in advance.
- Pricing includes delivery, material handling, installation and removal.
- All carpets, padding and plastic covering contain recycled content and are recyclable.
- Prestige, Custom Cut Classic Carpet, Turf and Vinyl are subject to a 100% Cancellation Charge.

10' Classic Carpet, Padding & Plastic Covering

Choose your carpet color:

- Black Blue* Gray Midnight Blue Red* Tuxedo

Qty	Description	Online Price	Discount Price	Standard Price	Total
_____	10' x 10' Classic Carpet	325.00	357.50	455.00	\$ _____
_____	10' x 20' Classic Carpet	650.00	715.00	910.00	\$ _____
_____	10' x 30' Classic Carpet	975.00	1072.50	1365.00	\$ _____
_____	10' x 10' Carpet Padding - Single Layer	180.00	198.00	252.00	\$ _____
_____	10' x 20' Carpet Padding - Single Layer	360.00	396.00	504.00	\$ _____
_____	10' x 30' Carpet Padding - Single Layer	540.00	594.00	756.00	\$ _____
_____	10' x 10' Carpet Padding - Double Layer	360.00	396.00	504.00	\$ _____
_____	10' x 20' Carpet Padding - Double Layer	720.00	792.00	1008.00	\$ _____
_____	10' x 30' Carpet Padding - Double Layer	1080.00	1188.00	1512.00	\$ _____
_____	Plastic Covering (price per sqft).....	0.70	0.75	1.00	\$ _____

Custom Cut Classic Carpet

- Order Custom Cut Classic Carpet by the sqft if your size is not listed on the standard size order form.
- Pricing includes plastic covering, delivery, material handling, installation and removal.

Choose your carpet color:

- Black Blue* Gray Green* Latte* Midnight Red* Red Pepper* Tuxedo*

16 oz. Carpet Rental - Price per sqft (100 sqft minimum)		Online Price	Discount Price	Standard Price	Total
Per sqft	Booth Size: _____ x _____ = _____ sqft @	5.55	6.10	7.75	\$ _____

Vinyl *

- Pricing includes delivery, material handling, installation and removal.
- 10' wide standard width

Choose your flooring color:

- Ash Birch Maple Smoke Walnut

10ft wide Vinyl - Price per sqft (100 sqft minimum)		Online Price	Discount Price	Standard Price	Total
Per sqft	Booth Size: _____ x _____ = _____ sqft @	8.70	9.55	12.20	\$ _____

NAME OF SHOW: **DBC PRI-MED EAST / DECEMBER 9 - 11, 2021**

COMPANY NAME: _____ BOOTH #: _____

CONTACT NAME: _____ PHONE #: _____

E-MAIL ADDRESS: _____

Prestige Carpet

- Pricing includes plastic covering, delivery, material handling, installation and removal.

28 oz Carpet, choose your carpet color:

- Black Cardinal* Charcoal* Cream* Gray Pearl Navy* Toast* Wedgewood* White*

28 oz. Carpet Rental - Price per sqft (100 sqft minimum)		Online Price	Discount Price	Standard Price	Total
1 - 700 sqft	Booth Size: _____ x _____ = _____ sqft @	6.50	7.15	9.10	\$ _____
Over 700 sqft	Booth Size: _____ x _____ = _____ sqft @	5.85	6.45	8.20	\$ _____

40 oz Carpet, choose your carpet color:

- Black* Charcoal* Gray Pearl* Navy* White*

40 oz. Carpet Rental - Price per sqft (100 sqft minimum)		Online Price	Discount Price	Standard Price	Total
1 - 700 sqft	Booth Size: _____ x _____ = _____ sqft @	7.50	8.25	10.50	\$ _____
Over 700 sqft	Booth Size: _____ x _____ = _____ sqft @	6.75	7.45	9.45	\$ _____

Carpet Padding

- Pricing includes delivery, material handling, installation and removal.
- Order padding by the sqft if your size is not listed on the standard size order form.

Carpet Padding - Price per sqft (100 sqft minimum)		Online Price	Discount Price	Standard Price	Total
100 - 700 sqft	Booth Size: _____ x _____ = _____ sqft @	1.80	2.00	2.50	\$ _____
Over 700 sqft	Booth Size: _____ x _____ = _____ sqft @	1.60	1.75	2.25	\$ _____

Double Carpet Padding - Price per sqft (100 sqft minimum)		Online Price	Discount Price	Standard Price	Total
100 - 700 sqft	Booth Size: _____ x _____ = _____ sqft @	3.60	3.95	5.05	\$ _____
Over 700 sqft	Booth Size: _____ x _____ = _____ sqft @	3.20	3.50	4.50	\$ _____

Vinyl Flooring Padding - Price per sqft (100 sqft minimum)		Online Price	Discount Price	Standard Price	Total
Per sqft	Booth Size: _____ x _____ = _____ sqft @	5.20	5.70	7.30	\$ _____

Turf *

- Pricing includes delivery, material handling, installation and removal.

Riviera Turf, choose your flooring color:

- Black Ivy Green

Riviera Turf - Price per sqft (100 sqft minimum)		Online Price	Discount Price	Standard Price	Total
Per sqft	Booth Size: _____ x _____ = _____ sqft @	6.10	6.70	8.55	\$ _____

Parkside Turf, choose your flooring color:

- Green

Parkside Landscape Turf - Price per sqft (100 sqft minimum)		Online Price	Discount Price	Standard Price	Total
Per sqft	Booth Size: _____ x _____ = _____ sqft @	13.10	14.40	18.35	\$ _____

TOTAL COST		
_____	+	_____ = \$ _____
Sub-Total	6.25 % Tax	Total Cost

FREEMAN

(888) 508-5054 Fax: (469) 621-5608
 ExhibitorSupport@freeman.com

NAME OF SHOW: **DBC PRI-MED EAST / DECEMBER 9 - 11, 2021**

COMPANY NAME: _____ BOOTH #: _____

CONTACT NAME : _____ PHONE #: _____

E-MAIL ADDRESS : _____

For fast, easy ordering, go to www.freeman.com/store.

CLEANING SERVICES

- **Cleaning is an exclusive service. This includes all floor services and trash removal.**
- Prices are based on total square footage of booth regardless of area to be cleaned.
- **Show Site Prices will apply to all cleaning orders placed at show site.**

VACUUMING (per sqft - 100 sqft minimum)

Qty (sqft)	Part #	Description	Advance Price	Show Site Price	Total
_____	610100	Booth Vacuuming - One Time95	1.35	_____
_____	610200	Booth Vacuuming - 2 Days	1.90	2.65	_____
_____	610300	Booth Vacuuming - 3 Days	2.85	4.00	_____

• Includes emptying of your booth's wastebasket(s) at the time of vacuuming.

SHAMPOOING (per sqft - 100 sqft minimum)

Qty (sqft)	Part #	Description	Advance Price	Show Site Price	Total
_____	630100	Shampoo Carpet - One Time	1.40	1.95	_____
_____	630200	Shampoo Carpet - 2 Days	2.80	3.90	_____
_____	630300	Shampoo Carpet - 3 Days	4.20	5.90	_____

PORTER SERVICE (per day)

Qty (# days)	Part #	Description	Advance Price	Show Site Price	Total
_____	620500	Exhibit Area / Under 500 sqft.	200.00	280.00	_____
_____	6201500	Exhibit Area / 501 - 1,500 sqft.....	250.00	350.00	_____
_____	6202500	Exhibit Area / 1,501 - 2,500 sqft.....	290.00	406.00	_____
_____	6203500	Exhibit Area / Over 2,500 sqft.....			Call for Quote

TOTAL COST

_____	+	_____	=	_____
Sub-Total		6.25 %Tax		Total Cost

FREEMAN

(888) 508-5054 • Fax: (469) 621-5608
ExhibitorSupport@freeman.com

NAME OF SHOW: **DBC PRI-MED EAST / DECEMBER 9 - 11, 2021**

COMPANY NAME: _____ BOOTH #: _____

CONTACT NAME: _____ PHONE #: _____

E-MAIL ADDRESS: _____

For fast, easy ordering, go to www.freeman.com/store.

DUMPSTER & DISPOSAL

DUMPSTER RENTAL

To order a dumpster for disposal of booth structures, please visit the Freeman Service Center.

DUMPSTER FEE

1/2 of a dumpster..... \$ 605.25 plus required labor
1 full dumpster.....\$1,210.50 plus required labor

DISPOSAL OF ITEMS LEFT IN BOOTH

If an Exhibitor fails to take down and dispose of booth properties (including but not limited to hardwall structures) that are left in the booth space at the close of the show, disposal charges will be incurred.

These charges may include the following:

- Installation & Dismantle Labor
- Forklift / Rigging Labor
- Dumpster Fee
- Equipment if deemed necessary

For Installation & Dismantle Labor Rates, see the Installation & Dismantle Labor Order Form.

For Rigging labor rates, please see the Forklift / Rigging Order Form.

To remove and/or destroy leftovers in the Exhibitor's booth, it will take a minimum of (1) hour forklift charge at the show site rate, plus a dumpster fee.

FREEMAN dumpster & disposal

SEEING IS BELIEVING

Quality graphics contribute significantly to the impact of your exhibit. With state-of-the-art design and printing capabilities, Freeman brings your banners, signage, and exhibit graphics to life in a larger-than-life way. Our graphics products redefine "high definition," which means your brand has never been seen like this before.

- Photo-quality / high-resolution printing on a variety of rigid and rolled material including honeycomb, foam, Polyfoam, PVC, acrylic, fabric, vinyl and mesh materials
- Grand Format printers provide high-resolution digital printing of single and double-sided banners in virtually any size
- Electronic file transfer, in-house printing, and company-wide procedure standardization allow us to control quality, cost and scheduling on a nationwide basis
- Extensive resources ensure that last minute repairs and replacements are handled efficiently as needed, no matter where your event may be located



Call customer service at the number listed on the Quick Facts. For fast, easy ordering, go to freeman.com

CREATING VISUAL EXCITEMENT

Quality graphics contribute significantly to the impact of your exhibit. Vivid colors and sharp images attract attention, build traffic, and communicate messages more effectively. Freeman has invested in the latest printing technology and has the skills to provide you with the finest high-resolution digital graphic reproduction available.

STATE-OF-THE-ART CAPABILITIES

Freeman can provide four-color, photo-quality, high-resolution digital printing in virtually any size for banners, signage, exhibit graphics, and more. Each Freeman location has stand-alone printing capabilities, along with two additional graphic locations for additional support and for special requirements.

SUPERIOR QUALITY CONTROL

Electronic file transfer, in-house printing, and company-wide standardization of procedures allow us to control quality, cost and scheduling for our customers on a nationwide basis. Last minute repairs and replacements are handled efficiently through our nationwide resources.

DEPTH OF RESOURCES

- 5M UV roll printers provide grand format, four-color, high-resolution digital printing of single and double-sided banners up to 16' wide and virtually any size with seams.
- 3M Dye Sublimation printers provide 10' fabric graphics that work perfectly in our SmartWall panel system.
- UV flatbeds print directly to a variety of ridged materials and offer a 100% recyclable graphic when using a cardboard substrate.
- Freeman offers 100% recyclable substrates that can save you money and the environment.
- Large format Eco-Solvent printers produce high quality graphics for wall, carpet and window applications.
- 3M high speed digital cutters allow for precise cutting of multiple panel applications and also custom router graphic panels.
- Computer-aided graphic design & layout available for your assistance.

REPRODUCTION AND INSTALLATION

- Suspended banners
- Accent graphic photo panels
- Large format signage and banners
- Logo reproduction
- Backlit displays and murals
- Four-color carpet image printing



FREEMAN

(888) 508-5054 Fax: (469) 621-5608
 ExhibitorSupport@freeman.com

**DISCOUNT PRICE
 DEADLINE DATE
 NOVEMBER 09, 2021**

graphics

NAME OF SHOW: **DBC PRI-MED EAST / DECEMBER 9 - 11, 2021**

COMPANY NAME: _____ BOOTH #: _____

CONTACT NAME: _____ PHONE #: _____

E-MAIL ADDRESS: _____

For fast, easy ordering, go to www.freeman.com/store.

GRAPHICS

To order your graphics, complete this order form and attach your sign copy or electronic file.
 Please see artwork guidelines for electronic files on page 2 of this form.
Note: All graphics are subject to a 100% Cancellation Charge.

DIGITAL GRAPHICS

Freeman has the capabilities to provide you with the finest digital graphic reproduction available. Capabilities include four-color, photo-quality, high-resolution digital printing virtually any size for banners, signage, exhibit graphics and more.

_____ L X _____ W = _____ sqft

_____ sqft \$ 22.60 per sqft discount price
 x or = \$ _____
 \$ 33.90 per sqft standard price

- Minimum order per graphic 9 sqft (1296 sqin)
- Double sqft for double-sided graphics
- Round sqft to next whole increment
- File conversion, retouching, cloning or color correcting may incur additional labor charges. (See reverse side for graphic guidelines.)

LARGE DIGITAL GRAPHICS

Please call an Exhibitor Sales Specialist for price quotes on graphics over 80 sqft.

File Information:
 Electronic File Name _____

Application _____
 PMS Colors _____

Backing Material:

- | | |
|---|--|
| <input type="checkbox"/> Freeman Foam (Foamcore) | <input type="checkbox"/> Masonite |
| <input type="checkbox"/> Freeman PVC (PVC) | <input type="checkbox"/> Plexi |
| <input type="checkbox"/> Freeman HD Foam (Gatorfoam) | <input type="checkbox"/> Freeman Honeycomb (Eco-Board) |
| <input type="checkbox"/> Freeman Polyfoam (Ultra Board) | <input type="checkbox"/> Other |

The product offered has recycled content or has eco-friendly attributes and is 100% recyclable according to the manufacturer's specifications.

Vertical Horizontal Use Your Judgment For Sign Layout

Special Instructions _____

STANDARD SIZES

CHOOSE YOUR SIZE:

QTY.	Discount Price	Standard Price	TOTAL
7" x 11" _____	54.55	81.85 =	_____
7" x 22" _____	56.30	84.45 =	_____
7" x 44" _____	69.60	104.40 =	_____
9" x 44" _____	90.20	135.30 =	_____
11" x 14" _____	54.55	81.85 =	_____
14" x 22" _____	67.80	101.70 =	_____
14" x 44" _____	141.00	211.50 =	_____
22" x 28" _____	141.00	211.50 =	_____
28" x 44" _____	206.70	310.05 =	_____

Note: File conversion, retouching, cloning or color may incur additional labor charges. (See reverse side for graphic guidelines.)

INDICATE YOUR SIGN COPY HERE:

* Please feel free to attach additional sign copy on separate page.

Vertical Horizontal Use Your Judgment For Sign Layout

Background Color: _____

Lettering Color: _____

TOTAL COST		
Sub-Total	+	6.25 % Tax
		=
		Total Cost

CUSTOMER GUIDELINES FOR SUBMITTING GRAPHICS ARTWORK

Our goal is to provide you with the best possible quality graphics for your event or exhibit. You can help us in that effort by providing digital art files using the following guidelines. If you are sending us completed, print-ready files, please pass the following information on to your graphics designer or art department. Artwork must be submitted in the proper resolution and/or file size to produce quality images. Please provide proper color matching information and proofs to ensure accurate color reproduction.

PLEASE PROVIDE THE FOLLOWING WHEN SUBMITTING ART

RASTER ART (photos, logos containing any continuous tone images):

- Art submitted at 1:1 (100%), resolution should be no less than 60 dpi (100 dpi preferred)
- Art submitted at 2:1 (50%), resolution should be no less than 120 dpi (200 dpi preferred)
- Art submitted at 4:1 (25%), resolution should be no less than 240 dpi (400 dpi preferred)

VECTOR ART:

- Logos should be vector and have outlined fonts (if provided as bitmap, please use high-res images)

FONTS and LINKS

- Supply all fonts used in your design (zip Mac fonts). If unsure how to collect fonts, convert them to outlines
- Supply all links used in your document. Use packaging feature if available. If unsure how to collect links, embed them in the file when saving.

COLOR

- If PMS color matching is required, please use original Pantone + Solid Coated swatches in your artwork. Modifying Pantone names will result in printing default color (CMYK)
- CMYK artwork will be produced "As Is". Our color output is balanced and vibrant.
- Convert RGB art to CMYK if possible.
- If you are sending Certified Color Proofs (Gracol, Swop, Fogra), please provide ICC file information used to print your samples. Best option would be to include ICC chart on your prints.

ARTWORK IN THE STRUCTURE

- Please note that any panels going in the metal frame will hide 1/4" of your art all the way around. If you have a continuous wall where individual panels are divided by metal, use 1.25" spacing in between each panel to account for gaps and the natural flow of the graphics.

ACCEPTABLE FILE SOFTWARE

We are capable of working with both PC and MAC based software, and can accept art created with the ADOBE Creative Suite - Illustrator, InDesign, and Photoshop

Always provide the following:

- Native files with fonts and links (zipped)
- High-res PDF-X/4 exports of the files

ACCEPTABLE FILE TYPES and SUPPORT FILES

NATIVE FILES:

- AI CLOUD (CC) file with Packaged supporting links and fonts. You may keep images linked but Packaging feature must be used.
- AI (CS6, CS5, CS4...) file with embedded links and outlined fonts
- EPS file with embedded links and outlined fonts
- INDD file with Packaged supporting links and fonts

PRINT FILES:

- High-res PDF-X/4 (preferred)
- AI with PDF content (choose this option when saving file)
- EPS files with embedded links and outlined fonts

RASTER OR BITMAP ART:

- Photoshop EPS (preferred, use 8-bit preview, Max, Quality JPG compression)
- PSD (make sure font layers are rasterized)
- TIFF, JPG (quality 8 and higher)

Mac users: Use Zip or Stuffit programs when submitting fonts other than OTF (Open Type Fonts)

WAYS TO SEND ARTWORK

- When placing an order online, your order confirmation will include a link to our secure file sharing library so you may upload your graphic files. If your order is faxed in, or if you are working directly with a Freeman team member, a link will be emailed to you when your order is processed.

UNION JURISDICTIONS BOSTON, MASSACHUSETTS

We have provided these definitions to acquaint you with specific guidelines for labor. If you have any questions once you have read this, please address them to Show Management or to Freeman directly.

The unpacking, erection, assembling, dismantling, and packing of displays and equipment may be done by full-time employees of an exhibiting company. The official labor contractor for the exposition will have skilled craftsmen to assist exhibitors who wish to hire labor to perform these services. Arrangements for all temporary labor should be made through the official service contractor. Official labor order forms are included in the exhibitor service manual.

MATERIAL HANDLING

Work rules require that the official material handling contractor off-load all equipment and display material from commercial carriers/common carriers or van lines. **The use of fork trucks, pallet jacks and lift gates are permitted only by personnel of the official material handling contractor.** Exhibitors are allowed to perform their own material handling, provided they meet all of the following criteria:

Personnel performing the work must be **bonafide, full-time company employees** of the exhibiting company.

They must be off-loading from a company owned truck or rental vehicle, or from a car, van or truck owned by personnel of the exhibiting company. All trucks, including co-owned or rental vehicles, over 24' in length will be off-loaded or loaded by the official material handling contractor.

They may use **only** hand-operated equipment, which they have provided; two-wheeled hand trucks and four-wheeled flat trucks are permitted. The use of fork trucks, pallet jacks, lift gates or any other mechanical equipment is not permitted by anyone other than the official drayage contractor.

BOOTH LABOR

Exhibitors are allowed to set-up and/or dismantle their own booths, provided that they use their own **bonafide, full-time employees**. Please advise them not to bring outside labor of any kind.

TIPPING

Our Work Rules prohibit the SOLICITATION of tips by any of our employees. Our employees are paid excellent wages denoting a professional status and we feel that tipping is not necessary. Should you be SOLICITED for a tip, please report the incident to our Service Center as soon as possible.

LET US DO THE HEAVY LIFTING

Freeman specialists are ready to assist you with all of your exhibit requests, from beginning to end. And when it comes to installing and dismantling exhibits, we make no exceptions. Whether it's shipping and storage, emergency on-site repairs, basic installation and dismantling or support service coordination, including electrical, furnishings and more, Freeman has the resources and capabilities to ensure the most successful show experience possible.



Call customer service at the number listed on the Quick Facts. For fast, easy ordering, go to www.freeman.com

Freeman installation & dismantling experts work closely with you to coordinate every phase of your trade show participation, including:

- Pre-planning and budget consultation
- Skilled labor coupled with support services coordination - electrical, furnishings, floral, transportation, and audio visual
- On-site supervisors with dedicated floor managers
- Full, in-house carpentry for emergency repairs and refurbishing
- Post-show evaluations focused on incremental improvement to meet rapidly changing market conditions based upon customer feedback
- Post-show evaluations that help identify small changes that make big impacts

ON-SITE SUPERVISION

You may wish to supervise labor on your own, but if you need assistance, Freeman installation & dismantling experts will get the job done as an extension of your team.

If You Use Freeman Staff

Exhibits can be set up prior to your arrival under the direction of Freeman I&D supervisors.



FREEMAN

(888) 508-5054 Fax: (469) 621-5608

ExhibitorSupport@freeman.com

NAME OF SHOW: **DBC PRI-MED EAST / DECEMBER 9 - 11, 2021**

COMPANY NAME: _____ BOOTH #: _____

CONTACT NAME: _____ PHONE #: _____

E-MAIL ADDRESS: _____

For fast, easy ordering, go to www.freeman.com/store.

INSTALLATION & DISMANTLE LABOR

Description	Advance Price	Show Site Price
Straight Time: 8:00 AM to 4:30 PM Monday through Friday.....	\$160.00	\$224.00
Overtime: 4:30 PM to 8:00 AM Monday through Friday, all day Saturday	\$216.00	\$302.50
Double Time: All day Sunday and Holidays	\$274.00	\$383.75

- **Show Site prices will apply to all labor orders placed at show site.**
- Price is per person/per hour.
- Start time guaranteed only at start of working day.
- One hour minimum per person - labor thereafter is charged in half (1/2) hour increments.
- Labor must be canceled in writing, 24 hours in advance to avoid a one (1) hour cancellation fee per worker.
- When scheduling dismantle labor, be sure to allow sufficient time for empty containers to be returned to your booth.
- Freeman supervised jobs will be completed at our discretion prior to show opening and before the hall must be cleared. **Please include setup plan/photo, special instructions & inbound shipping information with this order.**

INSTALLATION LABOR

Freeman Supervised Labor - Please complete the reverse side of this form.

- Installation of your exhibit will be completed at our discretion prior to show opening.
- The charge for this service is 30% of the total installation labor bill, with a minimum of \$45.00.

Emergency contact: _____ Phone Number: _____

Exhibitor Supervised Labor (Supervisor must check in at the Freeman Service Center to pick up labor)

Supervisor will be: _____ Phone Number: _____

Date	Start Time	No. of People	Approx. Hrs. per Person	Total Hrs.	Hourly Rate	Estimated Total Cost
_____	_____	_____	x _____	= _____	x _____	= \$ _____
_____	_____	_____	x _____	= _____	x _____	= \$ _____
Freeman Supervision (30%/\$45.00) = \$ _____						
6.25% (Tax) = \$ _____						(N/A)
Total Installation = \$ _____						

DISMANTLE LABOR

Freeman Supervised Labor - Please complete the reverse side of this form.

- Freeman is not responsible for product or literature that is not properly packed and labeled by exhibitor.
- The charge for this service is 30% of the total dismantle labor bill, with a minimum of \$45.00.

Emergency contact: _____ Phone Number: _____

Exhibitor Supervised Labor (Supervisor must check in at the Freeman Service Center to pick up labor)

Supervisor will be: _____ Phone Number: _____

Date	Start Time	No. of People	Approx. Hrs. per Person	Total Hrs.	Hourly Rate	Estimated Total Cost
_____	_____	_____	x _____	= _____	x _____	= \$ _____
_____	_____	_____	x _____	= _____	x _____	= \$ _____
Freeman Supervision (30%/\$45.00) = \$ _____						
6.25 % (Tax) = \$ _____						(N/A)
Total Dismantle = \$ _____						

installation & dismantle labor

NAME OF SHOW: **DBC PRI-MED EAST / DECEMBER 9 - 11, 2021**

COMPANY NAME: _____ BOOTH #: _____

CONTACT NAME: _____ PHONE #: _____

E-MAIL ADDRESS: _____

FREEMAN SUPERVISED LABOR

IN ORDER TO BETTER SERVE YOU - Please complete the following information if your display is to be set-up and/or dismantled by Freeman I&D and you will not be present to supervise the installation and/or dismantle.

INBOUND SHIPPING & SET-UP INFORMATION

Freight will be shipped to: Warehouse _____ Show Site _____ Date Shipped _____

Total No. of Pieces: Crates _____ Cartons _____ Fiber Cases _____

Setup Plan/Photo: Attached _____ To Be Sent With Exhibit _____ In Crate No. _____

Carpet: With Exhibit _____ Rented From Freeman _____ Color _____ Size _____

Electrical Placement: Drawing Attached _____ Drawing With Exhibit _____ Electrical Under Carpet _____

Comments: _____

Graphics: With Exhibit _____ Shipped Separately _____

Comments: _____

Special Tools/Hardware Required: _____

OUTBOUND SHIPPING INFORMATION

SHIP TO: _____

Select a Carrier:

Freeman Exhibit Transportation:
 No need to schedule your outbound shipment.
 Charges will appear on your Freeman invoice.
 Freeman will make arrangements for all
 Freeman Exhibit Transportation shipments.

Other Carrier:
 Carrier Name: _____
 Carrier Phone: _____
 Arrangements for pick-up by other carriers is the responsibility of the
 exhibitor.

Select Level of Service:

- 1 Day: Delivery next business day
- 2 Day: Delivery by 5:00 PM second business day
- Deferred: Delivery within 3-5 business days
- Standard Ground
- Specialized: Pad wrapped, uncrated or truckload

Freight Charges:

Same as ship to
 Bill To: _____

Select Shipment Options (if applicable)

- Have loading dock
- Inside delivery
- Pad wrap required
- Do not stack
- Lift gate required
- Air ride required
- Residential

In the event your selected carrier fails to show on final move-out day, please select one of the following options:

- Re-route via Freeman's choice
- Deliver back to the warehouse at exhibitor's expense

PLEASE NOTE: Freeman is not responsible for product or literature that is not properly packed and labeled by the exhibitor.

installation & dismantle labor

FREEMAN

(888) 508-5054 Fax: (469) 621-5608

ExhibitorSupport@freeman.com

NAME OF SHOW: **DBC PRI-MED EAST / DECEMBER 9 - 11, 2021**

COMPANY NAME: _____ BOOTH #: _____

CONTACT NAME: _____ PHONE #: _____

E-MAIL ADDRESS: _____

For fast, easy ordering, go to www.freeman.com/store.

FORKLIFT & RIGGING LABOR

Straight Time: 8:00 AM to 4:30 PM Monday through Friday
Overtime: 4:30 PM to 8:00 AM Monday through Friday, All day Saturday
Double Time: All day Sunday and Holidays

- **Show site prices will apply to all labor orders placed at show site**
- Start time guaranteed only at start of working day
- One hour minimum - labor thereafter is charged in half (1/2) hour increments
- Supervisor must check in at the Freeman Service Center to pickup labor
- When scheduling dismantle labor, be sure to allow sufficient time for empty containers to be returned to your booth

Part #	Description	Advance Price	Show Site Price
FORKLIFT LABOR			
304050	Forklift w/operator - up to 5,000 lbs - ST.....	\$418.50	\$586.00
304051	Forklift w/operator - up to 5,000 lbs - OT.....	\$543.00	\$760.25
304052	Forklift w/operator - up to 5,000 lbs - DT.....	\$671.50	\$940.25
3040100	Forklift w/operator - up to 10,000 lbs - ST.....	\$903.50	\$1,265.00
3040101	Forklift w/operator - up to 10,000 lbs - OT.....	\$1,028.00	\$1,439.25
3040102	Forklift w/operator - up to 10,000 lbs - DT.....	\$1,156.50	\$1,619.25
304040	Forklift w/operator - 4-Stage - ST.....	\$723.50	\$1,013.00
304041	Forklift w/operator - 4-Stage - OT.....	\$848.00	\$1,187.25
304042	Forklift w/operator - 4-Stage - DT.....	\$976.50	\$1,367.25
RIGGING LABOR			
3020100	Rigger - ST.....	\$160.00	\$224.00
3020101	Rigger - OT.....	\$216.00	\$302.50
3020102	Rigger - DT.....	\$274.00	\$383.75
EQUIPMENT			
3090600	Forklift Cage.....	\$ 60.00	\$ 84.00

INSTALLATION

Part #	Description	Start Date	Start Time	No. Equip/ People	Approx. Hrs. per Person	Total Hours	Hourly Rate	Estimated Total Cost

Describe work to be done: _____ Sub-Total \$ _____
 _____ 6.25% Tax \$ **(N/A)**
Total Installation \$ _____

DISMANTLE

Part #	Description	Start Date	Start Time	No. Equip/ People	Approx. Hrs. per Person	Total Hours	Hourly Rate	Estimated Total Cost

Describe work to be done: _____ Sub-Total \$ _____
 _____ 6.25% Tax \$ **(N/A)**
Total Dismantle \$ _____

NAME OF SHOW: **DBC PRI-MED EAST / DECEMBER 9 - 11, 2021**

COMPANY NAME: _____ BOOTH #: _____

CONTACT NAME: _____ PHONE #: _____

E-MAIL ADDRESS: _____

CORD INSTALLATION LABOR

	Advance	Show Site
Straight Time- 8:00 A.M. to 4:30 P.M. Monday through Friday	\$160.00	\$224.00
Overtime- 4:30 P.M. to 8:00 A.M. Monday through Friday, all day Saturday	\$216.00	\$302.50
Double Time- All Day Sunday and Holidays.....	\$274.00	\$383.75

•Price is per person/per hour
•Supervisor must check in at the Freeman Service Center to pick up labor
•Labor must be canceled in writing, 24 hours in advance to avoid a one (1) hour cancellation fee per worker

Utility services for all 120V power provided by the facility does not include the installation of cords to specific areas within the booth space. Freeman labor, display company labor or the exhibitor can perform this work. Rental carpeting and padding will not be installed until cord installation is completed.

***High voltage (208V and over), please contact the facility's electrical department.**

Freeman Supervised Labor

- Freeman must receive detailed blueprints/floor plan's for power distributed under carpet.
- Installation of electrical cords will be completed at our discretion prior to exhibitor move-in.
- The charge for this service is 30% of the total installation labor bill, with a minimum of \$45.00.
- A detailed floor plan must accompany this order.

Emergency Contact: _____ Phone Number: _____

Exhibitor Supervised Labor

Name of supervisor _____ Phone Number: _____

***Start times cannot always be guaranteed.**

- If no time is provided, labor will be available on a first-come, first serve basis only.
- Exhibitors supervising the labor themselves should visit the Freeman Service Center to pick up labor.
- Carpet will not be installed until cords have been laid.

Date	Start Time	No. of People		Approx. Hrs. per Person	Total Hrs.	Hourly Rate	Estimated Total Cost
_____	_____	_____	x	_____ = _____	@ \$ _____	= \$ _____	
_____	_____	_____	x	_____ = _____	@ \$ _____	= \$ _____	
Freeman Supervision (30%/\$45.00)						= \$ _____	
Total Installation						= \$ _____	

CORD DISMANTLE LABOR

- Dismantle labor will be charged at 50% of the total install time rounded to the next half hour (1 hour minimum)
- Cord dismantle will be done on straight time whenever possible.

Date	No. of People	Approx. Hrs. per Person	Total Hrs.	Hourly Rate	Estimated Total Cost
_____	_____	_____	x _____ = _____	@ \$ _____	= \$ _____

CORD RENTAL

Description	Price	Quantity
15' Flat Cord	\$25.00*	_____
25' Flat Cord	\$35.00*	_____
50' Flat Cord	\$45.00*	_____
Tape to cover cords	\$25.00/roll*	_____

There will be a minimum charge of \$25.00 to cover cords with tape.
Larger areas and multiple electrical drops may require more than one roll.

Subtotal	_____
6.25 % (Tax)	_____
Total Cost	_____

TERMS & CONDITIONS

1. Straight time rates apply to labor calls between the hours of 8:00 a.m. and 4:30 p.m., Monday through Friday. Overtime rates apply to labor calls before 8:00 a.m. and after 4:30 p.m., Monday through Friday, Saturdays, Double time rates apply to labor calls all day Sundays and Holidays.
2. Labor rates are based on current wage scales and are subject to change in the event of a wage increase after rates have been published.
3. A minimum charge of one hour is applicable to all labor requests. Additional time on the same day is billed in 1/2 hour increments. Continuations to another day are a minimum of 1 hour. A one hour minimum charge will apply to pick up cords.
4. Charges for labor commence at time of dispatch to service the labor call. A one hour minimum will apply if an exhibitor representative is not present at the time of call or reschedules the call, unless 24 hour advance notice is received in writing.
5. Labor charges will include the time for laborers to gather the necessary tools and material for the job, have their work checked by the client and return the tools and material to the supply area.
6. Every effort will be made to dispatch laborers as requested but start times cannot be guaranteed. 8:00 a.m. calls will be filled on a first come first served basis as orders are received.
7. Claims will not be considered, or adjustments made, unless filed in writing, by Exhibitor, prior to the close of the event.
8. Freeman is not responsible for any damage or loss caused by the loss of power beyond its control and Exhibitor agrees to hold Freeman, its officers, directors, employees and agents harmless from such power loss. IN NO EVENT SHALL FREEMAN BE LIABLE FOR ANY INDIRECT OR CONSEQUENTIAL DAMAGES (INCLUDING WITHOUT LIMITATION LOST PROFITS) EVEN IF ADVISED OF THE POSSIBILITY OF SUCH DAMAGES, WHETHER UNDER THEORY OF CONTRACT, TORT (INCLUDING NEGLIGENCE), PRODUCTS LIABILITY OR OTHERWISE. Exhibitor shall indemnify and hold harmless Freeman, its officers, directors, employees, and agents from and against any and all claims, liabilities, damages, fines penalties or costs of whatsoever nature (including reasonable attorneys' fees) arising out of or in any way connected with Exhibitor's actions or omissions under this Agreement.

EXAMPLE OF PLAN AND INFORMATION REQUIRED TO COMPLETE FLOORWORK

Please indicate the following on the floor plan.

1. Location and load of main power drop - please provide specific dimensions and wattages/amperages.
2. Location and load of all outlets - please provide specific dimensions and wattages/amperages.
3. Booth orientation - please provide surrounding aisle and/or booth numbers

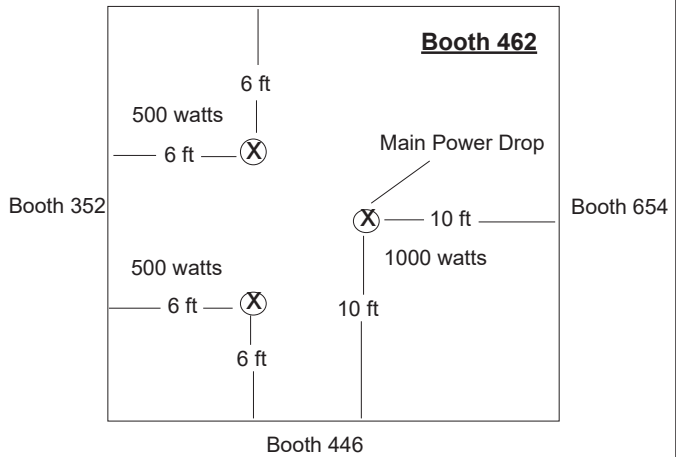

IN LINE BOOTHS

Power is run or dropped to in line booths along the back walls or drupe line of multi booth sections. The "main power locations" therefore are always located at the back of in line and peninsula booths. Outlets may not be in the exact center of the back wall. 120 volt outlets are shared by back to back booths.

Example: Outlet = ⊗

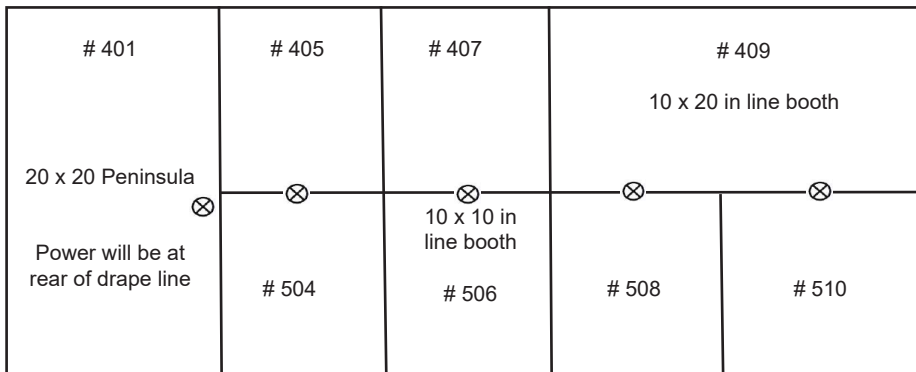

ELECTRICAL/INTERNET CORD LABOR GRID

SHOW NAME _____ DATES _____

COMPANY NAME _____ BOOTH # _____

ADJACENT AISLE OR BOOTH # _____

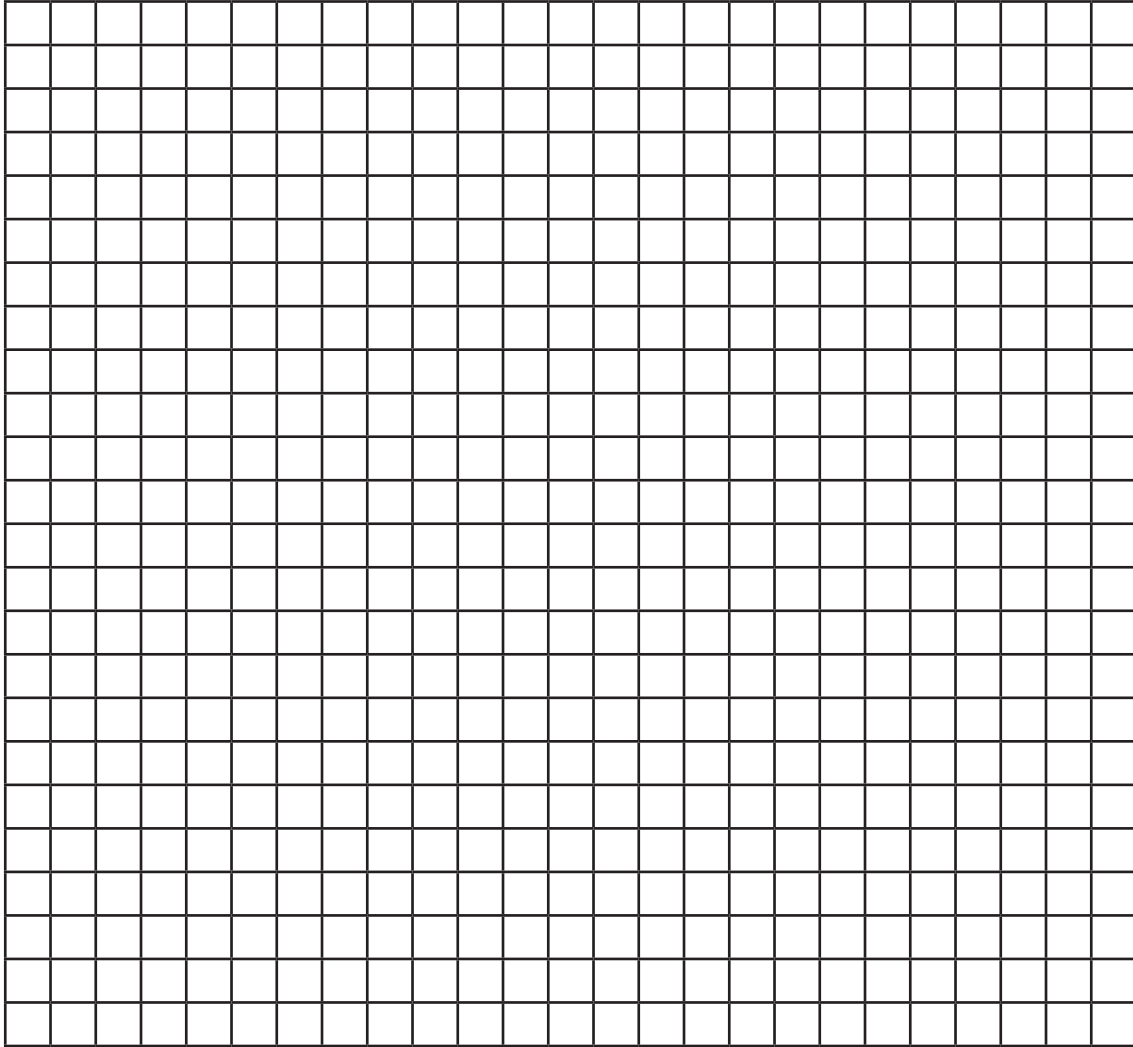

ADJACENT AISLE OR BOOTH # _____

A measurement scale can be applied to reflect the size of your booth.

10 x 10 use 1 square = 1/4 foot

20 x 20 use 1 square = 1/2 foot

40 x 40 use 1 square = 1 foot

Exhibitor Ordering Guide

BOSTON CONVENTION & EXHIBITION CENTER

JANUARY 1, 2021 - DECEMBER 31, 2021

Prepared Exclusively for:



Biotechnology
Industry
Organization



Signature
BOSTON™

Remarkable experiences.
Imagination realized.™

TABLE OF CONTENTS

Introduction	1
General Information	2
Electrical Services	3
Telephone Services	6
Internet & Technical Services	8
Rigging Services	12
Plumbing Services	17
Security Services	20
Appendix – Service Order Forms	21
Appendix – Exhibitor Guidelines, Information and Regulations	30
Appendix – Levy Restaurants Sample Food and/or Beverage Distribution Request	41



Introduction

On behalf of the Massachusetts Convention Center Authority, welcome to Boston!

We are excited to have you exhibit at our state-of-the-art facilities and look forward to working together to help you achieve your most ambitious goals. We are proud to offer the service, technology, and resources that will help you bring your vision to life. Our Exhibitor Services Team is an invaluable resource to assist you with transforming your ideas into an unforgettable event for your guests.

World-class customer service has become our signature as a meetings destination, which is why we have given our meetings and conventions experience a new name: Signature Boston. Unique and personal, a signature represents a promise that defines who we are and what we stand for. It speaks to our unwavering commitment to making every event we host in our city a success beyond your expectations.

This Ordering Guide is designed to make planning and ordering easy for all exhibitors. Each service section contains the following:

- Description of Services & Equipment and Pricing;
- Installation & Connection Information;
- Terms & Conditions, and;
- Frequently Asked Questions.

In addition to the orderable services listed in this guide, the MCCA also offers the following services for you to take advantage of on-site:

- Exhibitor Service Desk with assigned Event Associate
- Internet Support Services
- Free Wireless Internet Service
- FedEx Business Center

If you have any unanswered questions, please contact Exhibitor Services at 1.617.954.2230 or exhibitorservices@SignatureBoston.com, and we will be happy to assist you!

General Information

ORDERING POLICIES & PROCEDURES

Pricing

Discount, Standard and On-Site rates are available for most services. To qualify for the discount rate, order requests and payment must be received 21 days prior to the show opening. Standard rates will apply to orders received after this discount cut-off date and be effective through the before move-in begins. On-site rates will apply to orders received once move in has begun.

Ordering

Exhibitors are encouraged to submit orders online at our secure and easy-to-use website, www.SignatureBoston.com. Credit card payment is required for all online orders. Exhibitors who prefer to mail in their orders and pay by check will find our Service Order Forms in the Appendix of this guide. No telephone orders will be accepted.

Exhibitors should be aware of the following when placing orders:

- All payments must be in US currency;
- The date payment is received determines the applicable rate (see Pricing above);
- Incomplete order or payment information will delay processing;
- Booth number(s) must be identified on all order forms.

Payments

Payment for services must be received in advance. Service will be delivered only after payment is received. All outstanding charges must be paid before the close of the show. Please note that there will be no additional taxes added to service charges.

Refunds

Claims for refunds must be submitted by the exhibitor to Exhibitor Services prior to event close. Credit will not be given for services installed and not used. Refunds are issued in the same manner in which payment was received.

General Terms & Conditions

- All booth number changes must be communicated by the exhibitor to Exhibitor Services prior to exhibitor move-in. Additional charges may result, if services must be moved after initial set-up.
- All equipment and material furnished by the MCCA shall remain the property of the MCCA and shall be removed only by MCCA personnel.
- Standard wall outlets and other permanent building outlets (e.g., electrical, plumbing, etc.) are not part of the booth space and may not be used by anyone other than MCCA personnel or designated service provider.
- Service connections must be made by MCCA personnel or designated service provider.
- Connection services generally cover the installation of service to the booth area in the most convenient manner to the MCCA.
- All equipment must comply with state and local safety codes. MCCA will refuse connection to any equipment that constitutes a safety hazard.
- Unless otherwise directed, MCCA personnel are authorized to cut floor coverings to permit installation of services.

Electrical Services

The MCCA offers a variety of electrical services through our experienced in-house team of electricians.

SPECIAL CONNECTIONS (208 volt & 480 volt power)	DISCOUNT	STANDARD	ON-SITE
Unless otherwise indicated in parentheses (), all special power connections will be hard-wire connected. To order Three Phase 100 amp service and higher, please contact MCCA exhibitor services for availability.			
208v single phase 30 amp (nema l21-30p)	\$380.00	\$470.00	\$565.00
208v single phase 60 amp	\$720.00	\$895.00	\$1,075.00
208v single phase 100 amp	\$1,100.00	\$1,380.00	\$1,655.00
208v three phase 30 amp (nema l21-30p)	\$680.00	\$850.00	\$1,020.00
208v three phase 60 amp	\$1,030.00	\$1,285.00	\$1,545.00
Note: Any 100+ amp connection must be approved by MCCA Exhibitor Services. Please call 617.954.2230.			
208v three phase 100 amp	\$1,635.00	\$2,045.00	\$2,455.00
208v three phase 200 amp	\$3,115.00	\$3,900.00	\$4,680.00
208v three phase 400 amp	\$5,505.00	\$6,885.00	\$8,260.00
480v three phase 30 amp	\$1,040.00	\$1,295.00	\$1,555.00
480v three phase 60 amp	\$1,805.00	\$2,255.00	\$2,705.00
480v three phase 100 amp	\$3,325.00	\$4,160.00	\$4,995.00
480v three phase 200 amp	\$6,605.00	\$8,260.00	\$9,915.00

STANDARD CONNECTIONS (120 volt power)	DISCOUNT	STANDARD	ON-SITE
500 watt box One 5 amp circuit and one receptacle or plug point	\$135.00	\$165.00	\$195.00
1000 watt box One 10 amp circuit and two receptacles or plug points	\$175.00	\$215.00	\$260.00
2000 watt box One 20 amp circuit and a minimum of three receptacles or plug points	\$215.00	\$265.00	\$320.00
4000 watt box Two 20 amp circuits and a minimum of three receptacles or plug points	\$250.00	\$310.00	\$370.00

ADDITIONAL ELECTRICAL SERVICES & EQUIPMENT	DISCOUNT	STANDARD	ON-SITE
25' round extension cords 25' round, yellow extension cords for use in exhibit booths. Each cord has three, three-prong receptacles on the end. <i>*Please Note: These extension cords cannot be used to run underneath booth carpeting.</i>	\$40.00	\$45.00	\$55.00
6 Port Power Strip Purchase		\$25.00	\$25.00
24 hour power If booth equipment requires electricity 24 hrs a day (for example, a Refrigerator), then the exhibitor should order 24 hr power. In general, electrical service begins half an hour before the show and ends one hour after the show closes.		Add 50% to Initial Connection Rate	

OVERHEAD POWER

Overhead power is available upon approval by the MCCA:

- At the Boston Convention & Exhibition Center, overhead 120v electrical is limited due to the ceiling heights. Overhead service is available under the low mechanical roof on the East and West sides of the Halls.
- If an overhead sign, truss, banner or other rigged item requires overhead 120v power, the MCCA can provide this service in any area of the BCEC.
- If an overhead sign, truss, banner or other rigged item requires overhead 208v or 480v power, the MCCA can provide this service in limited areas of the BCEC. Please contact the MCCA Exhibitor Services team for availability.
- Overhead power must accompany a rigging order.

Installation & Distribution

- MCCA Electricians will provide the initial electrical power source.
- Electrical Service is brought from the nearest column or floor port into the booth. The electrical outlets or boxes are placed in the rear of the booth along the pipe & drape line.
- Electrical boxes are left accessible inside floor ports for island booths with no pipe and drape lines and no columns in their booth space.
- For 208V & 480V connections, we require floor plans so that we may provide the electrical service in a convenient location within the booth.
- Exhibitors are responsible for distributing their own 120V electrical cords and plugging in their booth equipment. Exhibitors may choose to:
 - » Hire labor from the General Service Contractor;
 - » Hire a third-party Installation & Dismantle (I&D) team to perform the distribution work;
 - » Bring their own company electrician to perform distribution and hardwire connections as long as he/she is a full time employee of the exhibiting company.

Terms & Conditions

- The MCCA is the exclusive provider of electrical service. All electrical equipment shall remain the property of the MCCA and may not be installed or removed by anyone other than MCCA personnel.
- All services listed include labor to install and remove said service. Rates do not include connecting of equipment, tracing of malfunctions, special wiring, or repairs. If an exhibitor requires additional electrical labor outside of the standard service, services will be billed at an hourly rate with a minimum of one hour. Labor rates are based on current wage and benefit rates and are subject to change without notice:
 - » Hourly Rate (All times) \$95.00
- The use of open clip sockets, duplex or triplex attachment plugs, latex or lamp cord is prohibited. All cords must be of the 3 wire grounded type and UL approved. Cords can be no smaller than 12 wire or 12 gauge. Any exposed non-current carrying metal parts of fixed equipment must be grounded.
- Electrical equipment must be properly tagged and wired with complete information as to type of current, voltage, phase, cycle, horsepower, etc.
- The MCCA cannot be responsible for voltage variations of the power company.

FREQUENTLY ASKED QUESTIONS

If the MCCA doesn't run my electrical cords, and I can't do it myself, who should I send my electrical layout plan to?

If you have booth floor plans that include electrical layouts, you should share that information with your preferred setup personnel. If you are working with a third-party exhibit company, they may run the cords for you. If you need to hire labor to run cords for you, the show's General Service Contractor can help you. Typically, the General Service Contractor will include an Electrical Cord Labor Form in the Exhibitor Kit. The MCCA is happy to keep any floor plans on file for reference. In fact, we recommend that you forward your electrical layouts to Exhibitor Services for all 208V and 480V connections so that we may place the initial drop in the most convenient location possible.

How do I know if I need a 208V or 480V connection?

Most exhibitors do not require special connections like a 208V or 480V connection. Many times, these types of electrical services are required for heavy equipment and/or specialized machinery. Kindly consult with the equipment manufacturer, name plate rating or installation technician for specific details. Exhibitors who bring their own distribution panels may need one of these special connections.

How do I know how much power I need to order?

When determining how much power to order for a booth, it is helpful to know how much total power is required for the equipment in your booth space. Below, we have outlined some standard electrical requirements (requirements may vary).

- Standard Laptop 250-550 watts
- Lead Retrieval 300-500 watts
- Standard Plasma TV 300-400 watts

Items like laptops, standard booth lights, and televisions may be grouped together on one circuit provided they do not exceed the overall limit of the circuit or the surge protection device. There is some equipment that requires its own circuit to run properly. For example, a microwave or refrigerator requires its own dedicated circuit, so a laptop and refrigerator should not use the same power source.

I am an International Exhibitor and my equipment requires a converter to step down from 220V to 208V. Can I rent a converter from the MCCA?

The MCCA does not rent or supply power conversion equipment. Exhibitors are required to bring their own to the show.

I can't find 208V or 480V overhead service listed on your online ordering site. How can I order this service?

208V & 480V overhead services are limited in our convention centers. All requests for such connections must be approved by an MCCA electrician; please contact MCCA Exhibitor Services for more information.

Telephone Services

The MCCA offers a variety of telephone services through our experienced in-house technicians.

STANDARD TELEPHONE SERVICES	DISCOUNT	STANDARD	ON-SITE
Single-Line Phone Service Service includes one phone number and rental of one hard wired digital display phone. Equipment must be returned at the close of show.	\$300.00	\$370.00	\$450.00
Multi-Line Phone Service Service includes one phone number with multiple line appearances and rental of one hard wired digital display phone. Equipment must be returned at the close of show.	\$435.00	\$540.00	\$650.00
Vonage Single Line App Service Service includes one phone number, no handset. This is an app based service available by downloading the Vonage app on a personal mobile device. Available for iPhone and Android	\$180.00	\$225.00	\$270.00
Vonage Multi-Line App Service Service includes one phone number, no handset. This is an app based service available by downloading the Vonage app on a personal mobile device. Available for iPhone and Android	\$250.00	\$325.00	\$375.00

ADDITIONAL TELEPHONE SERVICES AND EQUIPMENT	DISCOUNT	STANDARD	ON-SITE
Call Forward (per phone line) Allows user to send calls to another phone.	\$55.00	\$70.00	\$85.00
Voicemail (per phone line) Allows user to setup a custom greeting and receive messages from incoming callers.	\$55.00	\$70.00	\$85.00
Call Waiting (per phone line)	\$55.00	\$70.00	\$85.00
Unreturned Device Fee Phone device delivered with service. Only charged if not returned post show.	\$170.00	\$170.00	\$170.00

INSTALLATION & CONNECTIONS

- MCCA technicians typically provide a line that is long enough to run anywhere in your booth. Exhibitors may have their preferred setup personnel run their phone cord(s) under the carpet to desired locations, or they may hire the General Service Contractor to do so.
- All telephone equipment can be picked up at the MCCA Exhibitor Services Desk.

Terms & Conditions

- The MCCA is the exclusive provider of all telephone services. All telephone equipment shall remain the property of the MCCA and may not be installed or removed by anyone other than MCCA personnel.
- All MCCA telephone equipment must be returned to the Exhibitor Service Desk prior to the close of the show. Failure to return MCCA phones will result in a replacement fee.
- All services listed include labor to install and remove said service. Rates do not include connecting of equipment, tracing of malfunctions, special wiring, or repairs. If an exhibitor requires additional telephone labor outside of the standard service, services will be billed at an hourly rate with a minimum of one hour. Labor rates are based on current wage and benefit rates and are subject to change without notice.

FREQUENTLY ASKED QUESTIONS

How do I know if I need a single-line or a multi-line service?

Single-line phones are just like most household phones. They can be used for fax lines, credit card machines, standard telephones, and even to dial-up internet service (although we do not recommend this method of internet connectivity). A Multi-Line Service includes one phone number with multiple line appearances and rental of one digital display phone.

How do I receive my phone number, dialing instructions, and phone equipment?

Please visit the MCCA Exhibitor Services desk onsite to pick up your equipment. At this time you will receive assigned phone numbers and dialing instructions. This information can also be provided ahead of time if requested through Exhibitor Services.

How can I place international calls on my phone line?

All phone lines will have the ability to place local, US and International calls.

Internet & Technical Services

The MCCA offers a variety of Internet and Technical services through our experienced in-house team of technicians.

Wired Internet Connections

Exhibitors who order wired internet drops are provided with one internet connection and assistance, as needed, from our internal IT Support Services staff. All MCCA Internet services include one initial line regardless of how many IPs are ordered with the service. To have more than one computer connected at one time, exhibitors may bring their own switch or hub device and cables, or they may purchase a switch from the MCCA. Exhibitors are asked to read through the following service descriptions closely to ensure that the purchased service level is sufficient to meet their bandwidth requirements during the entirety of the show. Below are basic guidelines for ordering wired Internet services.

All services are delivered DHCP. Public IP addresses are available upon request with all of our managed services listed below. Public IP addresses are not available with our Basic Service Package. Managed Services requesting public IP addresses require manual configuration to each machine.

Custom orders for bandwidth above listed service levels below can be ordered on a case-by-case basis through the MCCA's Exhibitor Services Department at **617-954-2230** or **exhibitorservices@signatureboston.com**.

MANAGED SERVICES Manually configured services require entry of IP addresses into the device before the device may access the internet.	DISCOUNT	STANDARD	ON-SITE
Basic Service Package The Basic Service Package includes a private VLAN and subnet. This level is sufficient if the main use is for a basic internet connection, such as for e-mail or internet browsing. The Basic Service package may not be fast enough for streaming video or multi-purpose use. Public IP addresses are not available with this service.	\$995.00	\$1,060.00	\$1,270.00
1.54 Mbps Managed Service The 1.54 Mbps Managed Service Package includes a private VLAN and subnet. This level is sufficient if the main use is for a basic internet connection, such as e-mail, internet browsing, or standard definition video streaming. It may not be fast enough for multi-purpose use. Public IP addresses available upon request.	\$2,015.00	\$2,385.00	\$2,860.00
3 Mbps Managed Service The 3 Mbps has more bandwidth than the 1.54 Mbps service and includes a private VLAN and subnet. Public IP addresses are available upon request. This level is sufficient for basic e-mail and web browsing, standard definition video streaming, or can accommodate multiple Internet connections.	\$4,900.00	\$5,625.00	\$6,750.00
6 Mbps Managed Service The 6 Mbps has more bandwidth than the 3 Mbps service and includes a private VLAN and subnet. Public IP addresses are available upon request. This level is sufficient for 4 standard definition video streams, or a single HD video stream, or can accommodate multiple Internet connections.	\$8,290.00	\$9,550.00	\$11,460.00
10 Mbps Managed Service The 10 Mbps service includes a private VLAN and subnet. Public IP addresses are available upon request. This level is sufficient for 6 standard definition video streams, a single HD video stream, or can accommodate multiple Internet connections.	\$11,095.00	\$12,735.00	\$15,280.00

15 Mbps Managed Service The 15 Mbps service includes a private VLAN and subnet. Public IP addresses are available upon request. This level is sufficient for 2 HD video streams, or a single 4K stream, or can accommodate multiple Internet connections.	\$16,345.00	\$18,785.00	\$22,540.00
20 Mbps Managed Service The 20 Mbps service includes a private VLAN and subnet. Public IP addresses are available upon request. This level is sufficient for 3 HD video streams, or a single 4K stream, or can accommodate multiple Internet connections.	\$21,710.00	\$24,970.00	\$29,965.00
25 Mbps Managed Service The 25 Mbps service includes a private VLAN and subnet. Public IP addresses are available upon request. This level is sufficient for 4 HD video streams, or a single 4K stream, or can accommodate multiple Internet connections.	\$26,970.00	\$31,040.00	\$37,250.00
30 Mbps Managed Service The 30 Mbps service includes a private VLAN and subnet. Public IP addresses are available upon request. This level is sufficient for 5 HD video streams, or up to two 4K video streams, or can accommodate multiple Internet connections.	\$32,100.00	\$36,930.00	\$44,315.00
35 Mbps Managed Service The 35 Mbps service includes a private VLAN and subnet. Public IP addresses are available upon request. This level is sufficient for 5 HD video streams, or up to two 4K video streams, or can accommodate multiple Internet connections.	\$37,360.00	\$42,980.00	\$51,575.00
40 Mbps Managed Service The 40 Mbps service includes a private VLAN and subnet. Public IP addresses are available upon request. This level is sufficient for 6 HD video streams, or up to two 4K video streams, or can accommodate multiple Internet connections.	\$42,255.00	\$48,605.00	\$58,325.00

ADDITIONAL INTERNET SERVICES & EQUIPMENT	DISCOUNT	STANDARD	ON-SITE
Copper Patch/ Booth to Booth Connection Copper Patch is a method of connecting computers or network equipment that may be in different locations in the facility. Copper patches can transmit data, audio, and video. This is not available with the shared service.	\$355.00	\$450.00	\$540.00
Fiber Patch/ Booth to Booth Connection Fiber Patch is a method of connecting computers or network equipment that may be in different locations in the facility. Fiber patches can transmit data, audio, and video.	\$500.00	\$620.00	\$745.00
Switch-8 Port This switch can connect up to 7 computers or devices together, giving all access to the internet service ordered.	\$105.00	\$145.00	\$175.00
Switch-24 Port This switch can connect up to 23 computers or devices together, giving all access to the internet service ordered.	\$370.00	\$475.00	\$570.00
25' CAT 5e Cable	\$47.00	\$60.00	\$70.00
50' CAT 5e Cable	\$65.00	\$85.00	\$100.00
100' CAT 5e Cable	\$105.00	\$125.00	\$150.00
Ethernet Cable Coupler	\$18.00	\$22.00	\$27.00

TECHNICAL SERVICES	DISCOUNT	STANDARD	ON-SITE
Cable TV Service Cable TV service is basic business cable service provided by Comcast Cable. Service is provided to booths from floor boxes or columns.	\$260.00	\$325.00	\$390.00
CATV Tuner (Only available at the BCEC) For TVs that are not cable-ready (including some plasmas), the CATV tuner interprets the signal and allows you to tune the signal. It functions similar to your cable box at home.	\$62.00	\$78.00	\$95.00
CATV Tap Box A distribution box which allows up to 16 CATV feeds from a single cable tap.	\$215.00	\$265.00	\$320.00

* For advanced Technical Service offerings, consult the online ordering site or contact MCCA Exhibitor Services.

INSTALLATION & CONNECTIONS

- MCCA technicians will provide one initial network cable.
- Internet Service is brought from the nearest column or floor port into the booth.
- All MCCA internet services come with one initial line regardless of how many IPs are ordered with the service. To have more than one computer connected at one time, exhibitors may bring their own routing device and cables or may purchase a switch and purchase cables from the MCCA.
- Exhibitors are required to distribute their own internet cables.
- Exhibitors may choose to:
 - » Hire labor from the General Service Contractor or;
 - » Hire a third-party Installation & Dismantle (I&D) team to perform the distribution work.

Terms & Conditions

- The MCCA is the exclusive provider of internet services.
- All services listed include labor to install and remove said service. Services do not include connecting of equipment, tracing of malfunctions, special wiring, or repairs. If an exhibitor requires additional internet labor outside of the standard service, services will be billed at an hourly rate with a minimum of one hour. Labor rates are based on current wage and benefit rates and are subject to change without notice:
 - » Tech Rep (All times) \$125.00
 - » Network Engineer (All times) \$155.00
- The MCCA will provide an Ethernet connection to a shared data network attachment for the use of Exhibitor's directors, officers, employees and guests during the official dates of specified show.
- Exhibitor will be responsible for providing all hardware, software and other equipment and facilities needed to connect to the Ethernet and to use network attachment.
- The network attachment provided by the MCCA may be used only by the Exhibitor's directors, officers, employees and guest, agents, or consultants. The MCCA network

will facilitate communications between the company's authorized users and entities reachable through the national internet.

- The Exhibitor will promote efficient use of provided networks to minimize and avoid unnecessary network traffic and interference with the work of other users on interconnected networks.
- Users of MCCA networks shall not disrupt any of the MCCA networks or any other MCCA associated networks.
- MCCA networks shall not be used to transmit any communication where the meaning of the message, or its transmission or distribution, would violate any applicable law or regulation or would be highly offensive to the recipient or recipients thereof. Mass distribution of any message, including advertising, may not be broadcast or otherwise sent on an intrusive basis to any user of the MCCA network or any directly or indirectly attached network. When requested by a user of the networks, product information and other commercial messages are permitted to be transmitted. Discussion of a product's relative advantages and disadvantages by users of the product and vendors' response to those who pose questions about their products may be made available over the MCCA networks. Interpretation application and possible modification shall be within the sole discretion of MCCA.
- MCCA does not make any express or implied warranty of any kind specifically. There is no express or implied warranty of merchantability or fitness for a particular purpose for the services to be provided. The protocol used on the MCCA network call for end to end verification of the accuracy of any message and such verification is the sole responsibility of the purchasing company. Similarly, these protocols provide for end to end verification of the receipt of all the data that is transmitted. MCCA will not be responsible for any loss of data from delays, non-deliveries, incorrect deliveries, service interruptions, including those caused by the negligence, errors or omissions of the MCCA, or other losses or damages. Use of information obtained via the services provided hereunder is at purchasing company's own risk. Exhibitor is responsible for (a) the accuracy and/or quality of the information obtained or data transmitted through the MCCA network and (b) assuring that each message purchasing company sends or receives has been received.

- MCCA shall not be liable to Exhibitor for any damage arising from any event that is out of the control of the MCCA. Neither shall the MCCA be liable to Exhibitor for indirect, special, incidental, exemplary, consequential or any other form of money damage, including, but not limited to, lost profits, or of the loss of data or information of any kind, however caused, and arising out of or in connection with the performance of MCCA, or the provision of services or performance hereunder, whether based in contract, tort, or any other legal theory, and whether or not MCCA has been made aware of the possibility of such damages.
- In no event shall liability exceed a refund of amounts actually paid to MCCA by Exhibitor for this network attachment.
- The network attachment shall be made available to Exhibitor by MCCA before the beginning through the end of the specified conference.
- The MCCA will provide a network attachment via an Ethernet connection at the Exhibitor's booth. At its own expense, the Exhibitor is responsible for providing the computer, attachment to Ethernet, electric power and all other hardware and software required to use the network attachment.

FREQUENTLY ASKED QUESTIONS

I ordered a Managed Service that required IP Addresses.

How and when do I receive this information?

When you are onsite and ready to configure your computers, please visit the Exhibitor Services desk to retrieve your IP Information.

Do you have wireless internet?

The MCCA offers free wireless internet service throughout meeting rooms, lobbies, and expo halls; just open your internet browser and look for the BCEC Wireless Network. This service is designed for casual users and not guaranteed. If you are relying on the internet to showcase your product or services we strongly recommend a wired internet connection for guaranteed service.

I see that you don't offer hubs for sale. What is the difference between a hub and a switch? Can I bring my own hub or switch?

The MCCA offers switch devices for sale instead of hubs because switches are known to provide better performance with a lower failure rate. Exhibitors are welcome to provide their own hub or switch for all internet services.

What is bandwidth and how do I know how much I need?

Bandwidth is the "size of the pipe" that data can traverse. The bigger the bandwidth, the faster data can be transferred. To find out how much bandwidth you require, please consult with a technical representative in your company or look for program specifications listed with any demonstrations or downloads you plan to run.

I need to access my company's network while I'm exhibiting at your facility. Which service will allow me to do this?

Exhibitors who need to connect remotely to their company's network using a VPN (Virtual Private Network) with authentication information like passwords, certificates, or "tokens" can do so with any of our services, however they should confirm with their IT department for the use of DHCP or public IP address requirements.

What is a VLAN?

A VLAN (Virtual Local Area Network) allows a network of computers to behave as if they are connected to the same service even though they may actually be physically located in different areas around the facility. One of the biggest advantages of a VLAN is that when a computer is physically moved to a different location, it can stay on the same VLAN without any hardware reconfiguration.

I ordered a switch and cables, how and when do I get them?

When you are ready for your switch and internet cables, please visit the Exhibitor Services Desk.

Rigging Services

The MCCA provides rigging and overhead lighting services through our service contractor, JCALPRO.

Planning Ahead for Rigging & Lighting Services

Diagrams and booth layouts are essential for planning rigging and lighting services. In order to ensure efficient delivery of required services, Exhibitors must submit rigging plots, drawing, blueprints, or engineers' certification with their orders. Diagrams must include the location, dimensions and weight, and the height from the floor to the top of the suspended item. Diagrams must also show booth outline with aisles or neighboring booths marked for reference and orientation.

PACKAGE RIGGING SOLUTIONS The MCCA offers package rigging solutions for exhibitors with basic and straight forward sign hanging needs. To qualify for the packages, exhibitors must be flexible with regards to days and times of load-in and take-down.	DISCOUNT	STANDARD	ON-SITE
Basic Rigging Package This package includes all lifts, labor, and rigging equipment (cables, pipes, and hardware) necessary to install and take down one sign/banner weighing less than 150lbs, measuring less than 20' in length, and less than 175 square feet. The package service is provided during standard service hours, Monday-Saturday 7am – 12am, except holidays. If service is required outside these times, then a Team Labor Hour must be ordered in addition to the package.	\$1,806.00	\$2,168.00	\$2,601.00
Electrical Rigging Package This package includes the Basic Rigging Package plus labor to connect electrical service to an Exhibitor sign/banner. Overhead electrical service for rotator, motor or lighted sign must be ordered separately. Please see Electrical services section for details.	\$2,090.00	\$2,508.00	\$3,010.00
Team Labor Hour Exhibitors may request rigging service on Sundays, holidays or outside the package service hours (Monday-Saturday 7am – 12am). In this case, a Team Labor Hour must be ordered for each rigging package ordered. In addition, when receiving a custom quote for rigging and lighting, team labor hours will be quoted for all labor hours required that are not covered by the Rigging Packages such as building of truss, focusing and attachment of lights, and lighting maintenance.	\$284.00	\$342.00	\$410.00

Custom Rigging & Lighting Solutions

The MCCA/JCALPRO also offers customized rigging and lighting solutions for Exhibitors with more complex or unique requirements. This option is best suited for Exhibitors with larger signs, multiple signs, and/or overhead lighting needs.

Custom Rigging and Lighting Solutions still require flexibility in load in and load out time. If you require a specific load in or load out day and/or time, hourly rates may apply (see Terms and Conditions – Page 13).

Custom Rigging & Lighting solutions may only be ordered with a pre-arranged quote.

Please contact JCALPRO at 1.617.954.2345 to initiate this process. Quotes will be issued in an easy-to-order format, and will typically include a base Rigging Package for labor charges and some combination of the following items as necessary.

* For Custom Rigging please contact JCALPRO at 617.954.2345, as these services are not available for online ordering.

CUSTOM RIGGING SOLUTIONS	DISCOUNT	STANDARD	ON-SITE
Truss A truss is an aluminum structure used to create a lower “ceiling” to hang lighting or other suspended items. It is available in 5’, 8’, or 10’ sections which can be attached to create desired lengths or height.			
Truss 5’ Section – Silver 12”x12” Box	\$30.00	\$36.00	\$42.00
Truss 8’ Section – Silver 12”x12” Box	\$47.00	\$56.00	\$67.00
Truss 10’ Section – Silver 12”x12” Box	\$58.00	\$69.00	\$85.00
Truss 5’ Section – Black 12”x12” Box	\$41.00	\$49.00	\$58.00
Truss 8’ Section – Black 12”x12” Box	\$65.00	\$79.00	\$94.00
Truss 10’ Section – Black 12”x12” Box	\$82.00	\$98.00	\$117.00
Truss 5’ Section – Silver 20.5”x20.5” Box	\$52.00	\$62.00	\$75.00
Truss 8’ Section – Silver 20.5”x20.5” Box	\$85.00	\$101.00	\$120.00
Truss 10’ Section – Silver 20.5”x20.5” Box	\$105.00	\$125.00	\$151.00
Corner Block A corner block is an aluminum piece that attaches to truss to create a right angle.			
Corner Block – Silver 12”x12” Box	\$58.00	\$69.00	\$85.00
Corner Block – Black 12”x12” Box	\$75.00	\$91.00	\$109.00
Corner Block – Silver 20.5”x20.5” Box	\$82.00	\$98.00	\$117.00
Base Plate A base plate is used as a stand for ground supported truss or poles.	\$41.00	\$49.00	\$58.00
Rotator A rotator is a motor used to rotate a hanging sign.	\$174.00	\$210.00	\$252.00
Motor A motor is a motorized pulley that is rigged to the ceiling and attached to truss to achieve a desired height. Motors are also used to safely suspend heavier items that cannot be supported by cables alone. Motors are available in ¼ ton, ½ ton, and 1 ton capacities.	\$174.00	\$210.00	\$252.00

Cheeseboro A cheeseboro is a clamp used to attach two pieces of truss or pipe together.	\$7.00	\$8.00	\$10.00
Grapple A grapple is a connector that allows you to make a 90 degree connection between trusses.	\$13.00	\$16.00	\$19.00

LIGHTING FIXTURES A variety of lighting options are available to brighten exhibit space. While lights cannot be attached directly to our ceiling, lighting can be suspended above exhibit space by utilizing truss and motors.	DISCOUNT	STANDARD	ON-SITE
Source 4 Par (575 watt, 750 watt) This fixture is best used to create a wash effect or cover a larger area with light. It is available in 575 watt or 750 watt. Lenses are available in Very Narrow (VNSP), Narrow (NSP), Medium (MFL), Wide (WFL).	\$41.00	\$49.00	\$58.00
Source 4 Leko (575, 750 watt) This fixture is best used to create a spot light or to highlight specific spaces or objects. It is available in 575 watt or 750 watt. Lenses come in 19, 26, 36, 50 degrees to achieve the desired illumination from the light.	\$52.00	\$62.00	\$75.00
Par 64 (1000 watt) The Par 64 will deliver similar results as the S4Par, but there are no options for additional lenses. They are available in 1000 watts.	\$36.00	\$42.00	\$50.00

CUSTOM LIGHTING SOLUTIONS Lighting kits include a combination of Lekos, Source 4 Pars and Par 64s based on layout and design requirements. Price includes fixtures, fixture accessories and all necessary cables. Dimmer/control and labor are not included and must be ordered separately. Special Orders for larger kits are available upon request.	DISCOUNT	STANDARD	ON-SITE
Small Lighting Kit (4-6 lights)	\$215.00	\$259.00	\$310.00
Medium Lighting Kit (7-11 lights)	\$378.00	\$455.00	\$545.00
Large Lighting Kit (12-15 lights)	\$524.00	\$629.00	\$756.00
X-Large Lighting Kit (16-20 lights)	\$641.00	\$769.00	\$923.00

DIMMER RACKS & LIGHTING CONTROLS			
These items are optional with individual fixtures or small lighting kits, but mandatory with larger lighting kits. The dimmer rack is a large “outlet” that all lights plug into to create a central control location. A dimmer rack, depending upon size, can be placed in a booth or attached to the truss and kept in the air. The lighting console/control plugs into the dimmer rack to dim or control individual lights, groups of lights, or all lights at once. Electrical service is not included and must be ordered separately.	DISCOUNT	STANDARD	ON-SITE
Dimmer Control 1.2 x 4	\$94.00	\$112.00	\$135.00
Dimmer Control 2.4 x 12	\$174.00	\$210.00	\$252.00
Dimmer Control 2.4 x 24	\$372.00	\$448.00	\$537.00

Terms & Conditions

- JCALPRO is the exclusive rigging vendor at the Boston Convention & Exhibition Center (BCEC). If an exhibitor is exhibiting at the BCEC and requires rigging services for the booth, JCALPRO is the only vendor authorized to hang signs, banners, or lighting in the booth space.
- If an Exhibitor requires specific load-in/load-out dates and/or times, then a base rigging package may not be applicable. In this case, a special quote for required crew and lift equipment will be prepared using the following hourly labor and weekly lift rental rates:

HOURLY LABOR ITEMS	MON-SAT 7AM-12AM (EXCEPT HOLIDAYS)	SUNDAYS 7AM-5PM AND HOLIDAYS	SUNDAYS AFTER 5PM ALL DAYS 12AM-7AM
Crew Chief	\$104.00	\$156.00	\$208.00
Head Rigger	\$104.00	\$156.00	\$208.00
Rigger	\$93.00	\$139.00	\$185.00
Dept Head	\$79.00	\$119.00	\$158.00
Stagehand	\$74.00	\$111.00	\$148.00

WEEKLY LIFT RENTAL ITEMS	RATE
24'- 32' Scissor Lift	\$780.00
40'- 45' Boom Lift	\$988.00
60' Boom Lift	\$1,665.00

- All rigging must conform to the rules, regulations, and facility limitations of the MCCA and any show management regulations.
- All equipment, signs, products, etc. must be designed to suspend safely. Care must be taken to use only rated rigging hardware when designing, constructing or purchasing such items. Any equipment, signs, products etc. deemed to be unsafe for overhead suspension by MCCA/JCALPRO will be substituted or denied.
- The use of any type of tape/adhesive for attaching signs, banners, or decorations to the building walls or decorative surfaces is not permitted.
- All assembly of equipment, signs, products necessary prior to hanging, etc., will be the responsibility of the Exhibitor.
- Failure by Exhibitor to submit accurate diagrams prior to load-in will delay set-up and could incur additional cost.

FREQUENTLY ASKED QUESTIONS

How do I know if I qualify for the Basic Rigging Package Rate?

Find out the dimensions and weight of your sign. If your sign weighs less than 150 pounds and is less than 20' in length and less than 175 square feet and does not require electrical rigging, truss, or motors, you will qualify for the Basic Rigging Package. If your sign is motorized or needs electrical rigging (for example a rotating sign or a sign with lights), you qualify for the Electrical Rigging Package.

Can I order lighting to be suspended from the ceiling?

If you would like to order lights to brighten up your booth or illuminate specific objects, you will need to get a *quote* from JCALPRO. In most cases, lights cannot be attached to our ceilings. Instead we can provide you with truss, using motors, to create a lower "ceiling" and then hang lights from that truss. We will require a diagram showing your booth layout and exactly what you want illuminated in order to put together a quote.

Do I ship my sign to you to put it together?

No. Although JCALPRO provides labor to hang the sign, the General Service Contractor (GSC) handles all shipments. You may build your sign or hire the GSC to put it together for you. When the sign has arrived at the building and has been assembled, we will hang it for you. Be sure to keep this in mind when making your time and day requests for sign hanging.

Can I request load in and load out times?

Yes, the Rigging Order Form has a space for you to indicate your preferred up and down times. Please note that your preferred timing is not guaranteed; however, we do try our best to cater to your requests. If you absolutely need a specific install or take down time, additional charges will apply. If you do not provide a diagram or layout prior to load-in, then you may experience set-up delays and additional cost.

What type of diagrams should I send?

The most useful diagrams are on a proportioned grid to show the dimensions of the booth, the exact desired placement of hanging items, and orientation of the booths around yours. As a general rule, pictures from previous shows and pictures of the sign only are not as helpful as current diagrams of the entire booth space with the placement, height, and weight of the sign(s) or hanging item(s).

Plumbing Services

The MCCA offers a variety of plumbing services through our experienced in-house team of plumbers.

WATER AND DRAIN SERVICES	DISCOUNT	STANDARD	ON-SITE
Water – Individual Connection Water service is available at approximately 75 PSI with up to ¾” supply line. Water flows at five gallons per minute. Please note that this is cold water.	\$345.00	\$440.00	\$530.00
Additional Water Connections Clients requiring more than an individual water connection should order each additional connection as needed.	\$205.00	\$255.00	\$305.00
Drain – Individual Connection The MCCA can provide waste drain connections up to ¾” line size.	\$345.00	\$440.00	\$530.00
Additional Drain Connections Clients requiring more than an individual drain connection should order each additional connection as needed.	\$190.00	\$235.00	\$280.00
Fill and Drain 0-100 Gallons Clients that need equipment to be filled with water at the beginning of a show and emptied at the end of a show should order a Fill and Drain service. Please contact your MCCA Event Services Manager when equipment is ready to be filled.	\$180.00	\$220.00	\$265.00
Each Additional 500 Gallons	\$115.00	\$155.00	\$185.00

SINK RENTALS	DISCOUNT	STANDARD	ON-SITE
Cold Water Sink Rental Cold water sink rental includes a single-tub basin (20”L x 24”W x 34”H), one water connection, and one drain connection. Legs allow the units to sit 34” above the floor.	\$705.00	\$870.00	\$1,045.00
Small Hot & Cold Water Sink Rental Small Hot & Cold water sink rental includes a single-tub basin (20”L x 24”W x 34”H), a hot water heater (6 gallon capacity), dedicated power, two water connections, and one drain connection.	\$940.00	\$1,165.00	\$1,400.00
Large Hot & Cold Water Sink Rental Large Hot & Cold water sink rental includes a 3-tub basin (57”L x 24.5”W x 43”H), a hot water heater (6 gallon capacity), dedicated power, two water connections, and one drain connection. This service is available in specific areas of the exhibition hall. Please contact your MCCA Event Services Manager for more information.	\$1,165.00	\$1,465.00	\$1,760.00

COMPRESSED AIR AND GASSES	DISCOUNT	STANDARD	ON-SITE
Compressed Air – Individual Connection Compressed Air is delivered at approximately 110 psi and a dew point of 35 degrees F (medical instrument quality).	\$430.00	\$530.00	\$635.00
Additional Connection Clients who require more than an individual connection should order additional connections as needed.	\$220.00	\$275.00	\$330.00
Other Compressed Gases The MCCA provides a variety of bottled gases. The most commonly ordered gases are listed below. If other gases not listed are required, the client should contact their MCCA Event Services Manager. Flammable gases are not permitted in MCCA facilities.			
20 Lbs Dry or Liquid CO ₂	\$180.00	\$215.00	\$260.00
50 Lbs Dry or Liquid CO ₂	\$200.00	\$235.00	\$280.00
Dry Nitrogen 300 ft ³	\$240.00	\$290.00	\$350.00

INSTALLATION & CONNECTIONS

- Plumbing Service is brought from the nearest column or floor port into the booth.
- Air and Water connections are available in limited locations on the exhibit floor. Connection sizes and booth locations all factor into planning to supply air and water to exhibitors. Please provide a floor plan of the exhibit space indicating locations that require air or water service as well as connection requirements well in advance of exhibitor move-in.

Terms & Conditions

- The MCCA is the exclusive provider of all plumbing services. All plumbing equipment shall remain the property of the MCCA and may not be installed or removed by anyone other than MCCA Personnel.
- Exhibitors are not permitted to fill or drain their own equipment, use individual air compressors, or bring their own compressed gases from an outside vendor.
- All services listed include labor to install and remove said service. Rates do not include connecting of equipment, tracing of malfunctions, special wiring, or repairs. If an

exhibitor requires additional plumbing labor outside of the standard service, services will be billed at an hourly rate with a minimum of one hour. Labor rates are based on current wage and benefit rates and are subject to change without notice:

» Hourly Rate (All times) \$95.00

FREQUENTLY ASKED QUESTIONS

Do all water connections need a drain?

While most water connections do require a drain service, there are some cases where the drain is unnecessary. When the water provided is being consumed or evaporated, a drain is not needed. For example, exhibitors using water service for a coffee machine do not need to order a drain because the water is being consumed.

Will you provide the fittings and hoses for my water and drain connections?

To ensure that your booth's equipment runs properly we ask that you supply your own regulators, filters, and hoses.

When would I need to order a Fill and Drain Service?

Some of the most common reasons exhibitors order fill and drain are for items like fish tanks, pools, tubs for display, or running water displays. We use large hoses to fill vessels requiring water and then use existing drains in the floor to remove the water at the end of the show. Exhibitors are not permitted to bring their own water or use MCCA sinks to fill their own equipment.

My booth requires a sprinkler system. What plumbing service should I order?

If your booth requires a sprinkler system, you will need to order an individual water connection specifically for this purpose.

My exhibitor kit says I need to order a hand washing unit because I am planning to prepare food in my booth. Do you provide these units?

Levy Restaurants, our exclusive in-house catering company, can provide a hand washing unit that includes a small hand washing sink, paper towels, soap, and a discard bucket. Please consult your exhibitor kit for Levy Restaurants information or contact them directly at the BCEC (617.954.2382).

Do you allow Exhibitors to bring Helium balloons into your buildings?

No, unfortunately we do not allow exhibitors to bring helium balloons into the buildings.

Security Services

The MCCA is the “preferred” provider of security booth coverage for exhibitors. If your event designates another security vendor for booth coverage, you may choose to order through the event’s preferred provider as detailed in your exhibitor kit.

SECURITY GUARD (BOOTH)	DISCOUNT	STANDARD	ON-SITE
<p>Per Hour Per Officer The MCCA offers uniformed public safety officers to cover shows and events. Officers are scheduled at a 4-hour minimum and are available from move-in to move-out, around the clock. Orders need to be placed 21 days in advance of the show/event opening in order to guarantee your requested coverage. Any orders received after the 21 day cut-off are subject to approval and are not guaranteed.</p>	\$32.00	\$38.50	\$46.00
<p>Per Hour Per Supervisor</p>	\$43.50	\$52.00	\$62.50

FREQUENTLY ASKED QUESTIONS

When do you recommend ordering security for an exhibitor booth?

Our public safety department strongly suggests ordering security for booths planning to have VIP celebrity appearances, book signings etc., to monitor crowd control and escort as needed. Also, exhibitors with expensive or rare equipment in their booths may consider security for the overnight hours between show end and the next day’s show start.

Is there general overnight security in the exhibit hall?

The MCCA provides 24 hour security coverage for the facility; however, security coverage for the exhibit hall is determined by the show organizer and may vary from event to event.

APPENDIX – SERVICE ORDER FORMS

Request for Exhibitor Electrical Services	22
Request for Telephone Services	23
Request for Internet & Technical Services	24
Request for Rigging & Lighting Services	26
Request for Exhibitor Plumbing Services	28
Request for Exhibitor Security Services	29

APPENDIX –

Exhibitor Guidelines, Information and Regulations	30
Levy Restaurants Sample Food and/or Beverage Distribution Request	41

**Exhibitor Order Form
Electrical Services**

Effective January 1, 2021

By submitting this order form, Exhibitor acknowledges and accepts all Policies, Terms & Conditions for service as set forth in the MCCA Exhibitor Ordering Guide available at <http://www.signatureboston.com/bcec/bcec-ordering-guide.aspx>.
To qualify for discount rate, request and payment must be received 21 days prior to show/event opening.

***Overhead electrical services must accompany a rigging order.**

Incomplete information will delay processing.

Event or Show:		Booth no. (s)			
Event or show date(s):		Exhibiting firm:			
Billing address:	City:	State:	Zip:	Country:	
Phone:		Email:			
Ordered by/title:		Show site contact:			
Date:		Contact phone:			

STANDARD ELECTRICAL CONNECTIONS: 120 VOLT

Description	Regular Service			Additional Services Available as Add-Ons					Total Due: \$
	QTY	Discount Rate	Standard Rate	QTY	24-Hour Service	QTY	Overhead Service*	QTY	
500 Watt Box (5 amps)		\$135.00	\$165.00		+50% rate		\$165.00		\$247.50
1000 Watt Box (10 amps)		\$175.00	\$215.00		+50% rate		\$215.00		\$322.50
2000 Watt Box (20 amps)		\$215.00	\$265.00		+50% rate		\$265.00		\$397.50
4000 Watt Box (20 amps x 2)		\$250.00	\$310.00		+50% rate		\$310.00		\$465.00

STANDARD ELECTRICAL CONNECTIONS: 208 VOLT & 480 VOLT

Description	Regular Service			Additional Services Available as Add-Ons					Total Due: \$
	QTY	Discount Rate	Standard Rate	QTY	24-Hour Service	QTY	Overhead Service*	QTY	
208V Single Phase 30 Amp		\$380.00	\$470.00		+50% rate		\$470.00		\$705.00
208V Single Phase 60 Amp		\$720.00	\$895.00		+50% rate		\$895.00		\$1,342.50
208V Single Phase 100 Amp		\$1,100.00	\$1,380.00		+50% rate		\$1,380.00		\$2,070.00
208V Three Phase 30 Amp		\$680.00	\$850.00		+50% rate		\$850.00		\$1,275.00
208V Three Phase 60 Amp		\$1,030.00	\$1,285.00		+50% rate		\$1,285.00		\$1,927.50
208V Three Phase 100 Amp		\$1,635.00	\$2,045.00		+50% rate		\$2,045.00		\$3,067.50
208V Three Phase 200 Amp		\$3,115.00	\$3,900.00		+50% rate		\$3,900.00		\$5,850.00
208V Three Phase 400 Amp		\$5,505.00	\$6,885.00		+50% rate		\$6,885.00		\$10,327.50
480V Three Phase 30 Amp		\$1,040.00	\$1,295.00		+50% rate		\$1,295.00		\$1,942.50
480V Three Phase 60 Amp		\$1,805.00	\$2,255.00		+50% rate		\$2,255.00		\$3,382.50
480V Three Phase 100 Amp		\$3,325.00	\$4,160.00		+50% rate		\$4,160.00		\$6,240.00
480V Three Phase 200 Amp		\$6,605.00	\$8,260.00		+50% rate		\$8,260.00		\$12,390.00
25' Round Extension Cord		\$40.00	\$45.00						
6 Port Power Strip Purchase			\$25.00						

Total Due: \$

SIGNATURE _____

To pay with a Discover, MasterCard, Visa or American Express, you may order online at www.signatureboston.com.

To pay with a check, send a check payable to Massachusetts Convention Center Authority and this form to:

EXHIBITOR SERVICE CENTER | MASSACHUSETTS CONVENTION CENTER AUTHORITY | 415 SUMMER STREET | BOSTON, MASSACHUSETTS 02210
 617.954.2230 EXHIBITORSERVICES@SIGNATUREBOSTON.COM TAX ID#: 042768982

FOR MCCA USE ONLY

Date Received:	Received by:	Check Number:	Discover/MC/Visa/Amex:
----------------	--------------	---------------	------------------------

**Exhibitor Order Form
Telephone Services**

Effective January 1, 2021

By submitting this order form, Exhibitor acknowledges and accepts all Policies, Terms & Conditions for service as set forth in the MCCA Exhibitor Ordering Guide available at <http://www.signatureboston.com/bcec/bcec-ordering-guide.aspx>.
To qualify for discount rate, request and payment must be received 21 days prior to show/event opening.

Incomplete information will delay processing.

Event or Show:		Booth no. (s)		
Event or show date(s):		Exhibiting firm:		
Billing address:	City:	State:	Zip:	Country:
Phone:		Email:		
Ordered by/title:		Show site contact:		
Date:		Contact phone:		

STANDARD TELEPHONE SERVICES	QTY	DISCOUNT RATE	STANDARD RATE	TOTAL DUE: \$
Single-Line Phone Service		\$300.00	\$370.00	
Multi-Line Phone Service		\$435.00	\$540.00	
Vonage Single Line App Service		\$180.00	\$225.00	
Vonage Multi-Line App Service		\$250.00	\$325.00	

ADDITIONAL TELEPHONE SERVICES & EQUIPMENT	QTY	DISCOUNT RATE	STANDARD RATE	TOTAL DUE: \$
Call Forward (per phone line)		\$55.00	\$70.00	
Voicemail (per phone line)		\$55.00	\$70.00	
Call Waiting (per phone line)		\$55.00	\$70.00	

Total Due: \$

SIGNATURE _____

 To pay with a Discover, MasterCard, Visa or American Express, you may order online at www.signatureboston.com.

To pay with a check, send a check payable to Massachusetts Convention Center Authority and this form to:

 EXHIBITOR SERVICE CENTER | MASSACHUSETTS CONVENTION CENTER AUTHORITY | 415 SUMMER STREET | BOSTON, MASSACHUSETTS 02210
 617.954.2230 EXHIBITORSERVICES@SIGNATUREBOSTON.COM TAX ID#: 042768982

FOR MCCA USE ONLY			
Date Received:	Received by:	Check Number:	Discover/MC/Visa/Amex:

**Exhibitor Order Form
Internet & Technical
Services**

Effective January 1, 2021

By submitting this order form, Exhibitor acknowledges and accepts all Policies, Terms & Conditions for service as set forth in the MCCA Exhibitor Ordering Guide available at <http://www.signatureboston.com/bcec/bcec-ordering-guide.aspx>.
To qualify for discount rate, request and payment must be received 21 days prior to show/event opening.

Incomplete information will delay processing.

Event or Show:		Booth no. (s)		
Event or show date(s):		Exhibiting firm:		
Billing address:	City:	State:	Zip:	Country:
Phone:		Email:		
Ordered by/title:		Show site contact:		
Date:		Contact phone:		

WIRED INTERNET CONNECTIONS: MANUAL CONFIGURATION	QTY	DISCOUNT RATE	STANDARD RATE	TOTAL DUE: \$
Basic Service Package (includes a private VLAN and subnet, public IP addresses not available)		\$995.00	\$1,060.00	
1.54 Mbps Managed Service (includes a private VLAN and subnet, public IP addresses available upon request)		\$2,015.00	\$2,385.00	
3 Mbps Managed Service (includes a private VLAN and subnet, public IP addresses available upon request)		\$4,900.00	\$5,625.00	
6 Mbps Managed Service (includes a private VLAN and subnet, public IP addresses available upon request)		\$8,290.00	\$9,550.00	
10 Mbps Managed Service (includes a private VLAN and subnet, public IP addresses available upon request)		\$11,095.00	\$12,735.00	
15 Mbps Managed Service (includes a private VLAN and subnet, public IP addresses available upon request)		\$16,345.00	\$18,785.00	
20 Mbps Managed Service (includes a private VLAN and subnet, public IP addresses available upon request)		\$21,710.00	\$24,970.00	
25 Mbps Managed Service (includes a private VLAN and subnet, public IP addresses available upon request)		\$26,970.00	\$31,040.00	
30 Mbps Managed Service (includes a private VLAN and subnet, public IP addresses available upon request)		\$32,100.00	\$36,930.00	
35 Mbps Managed Service (includes a private VLAN and subnet, public IP addresses available upon request)		\$37,360.00	\$42,980.00	
40 Mbps Managed Service (includes a private VLAN and subnet, public IP addresses available upon request)		\$42,255.00	\$48,605.00	

CONTINUED ON PAGE 25

ADDITIONAL SERVICES & EQUIPMENT		QTY	DISCOUNT RATE	STANDARD RATE	TOTAL DUE: \$
Copper Patch / Booth to Booth Connection			\$355.00	\$450.00	
Fiber Patch/ Booth to Booth Connection			\$500.00	\$620.00	
Switch	8 port		\$105.00	\$145.00	
	24 port		\$370.00	\$475.00	
25' CAT 5e Cable			\$47.00	\$60.00	
50' CAT 5e Cable			\$65.00	\$85.00	
100' CAT 5e Cable			\$105.00	\$125.00	
Ethernet Cable Coupler			\$18.00	\$22.00	

TECHNICAL SERVICES		QTY	DISCOUNT RATE	STANDARD RATE	TOTAL DUE: \$
Cable TV Service			\$260.00	\$325.00	
CATV Tuner Rental (Only available at the BCEC)			\$62.00	\$78.00	
CATV Tap Box			\$215.00	\$265.00	
					Total Due: \$

SIGNATURE _____

To pay with a Discover, MasterCard, Visa or American Express, you may order online at www.signatureboston.com.
 To pay with a check, send a check payable to Massachusetts Convention Center Authority and this form to:

EXHIBITOR SERVICE CENTER | MASSACHUSETTS CONVENTION CENTER AUTHORITY | 415 SUMMER STREET | BOSTON, MASSACHUSETTS 02210
 617.954.2230 EXHIBITORSERVICES@SIGNATUREBOSTON.COM TAX ID#: 042768982

FOR MCCA USE ONLY			
Date Received:	Received by:	Check Number:	Discover/MC/Visa/Amex:



**Exhibitor Order Form
Rigging Services**

Effective January 1, 2021

By submitting this order form, Exhibitor acknowledges and accepts all Policies, Terms & Conditions for service as set forth in the MCCA Exhibitor Ordering Guide available at <http://www.signatureboston.com/bcec/bcec-ordering-guide.aspx>. **To qualify for discount rate, request and payment must be received 21 days prior to show/event opening.**

Incomplete information will delay processing.

Event or Show:		Booth no. (s)		
Event or show date(s):		Exhibiting firm:		
Billing address:	City:	State:	Zip:	Country:
Phone:		Email:		
Ordered by/title:		Show site contact:		
Date:		Contact phone:		

ITEM DESCRIPTION & INFORMATION

**Description of Item (Sign, Banner, Truss, etc.)

Quantity:	Size:	Weight:	Height desired from floor to top of suspended item:
Do any items require Electrical service (circle one)? YES NO		Indicate Service Ordered on Electrical Form:	
Date When Your Item Will Be Ready for Hanging:		Preferred Move-Out Date:	

PACKAGE RIGGING SOLUTIONS

Service Description	QTY	Discount Rate	Standard Rate	Total Due: \$
Basic Rigging Package (Per Sign/Banner)		\$1,806.00	\$2,168.00	
Electrical Rigging Package (Per Sign/Banner)		\$2,090.00	\$2,508.00	
Team Labor Hour		\$284.00	\$342.00	

CUSTOM RIGGING SOLUTIONS - RIGGING EQUIPMENT RENTAL (REQUIRES QUOTE*)

*For any of the services below, please contact JCALPRO at 617.954.2345.

Equipment Description	QTY	Discount Rate	Standard Rate	Total Due: \$
Silver 12" x 12" Box Truss	5' Section		\$30.00	\$36.00
	8' Section		\$47.00	\$56.00
	10' Section		\$58.00	\$69.00
Black 12" x 12" Box Truss	5' Section		\$41.00	\$49.00
	8' Section		\$65.00	\$79.00
	10' Section		\$82.00	\$98.00
Silver 20.5" x 20.5" Box Truss	5' Section		\$52.00	\$62.00
	8' Section		\$85.00	\$101.00
	10' Section		\$105.00	\$125.00
Corner Block	Silver 12" x 12" box		\$58.00	\$69.00
	Black 12" x 12" box		\$75.00	\$91.00
	Silver 20.5" x 20.5" box		\$82.00	\$98.00
Base Plate		\$41.00	\$49.00	
Rotator		\$174.00	\$210.00	
Motor		\$174.00	\$210.00	
Cheeseboro		\$7.00	\$8.00	
Grapple		\$13.00	\$16.00	

CONTINUED ON PAGE 27

CUSTOM LIGHTING SOLUTIONS – LIGHTING EQUIPMENT RENTAL (REQUIRES QUOTE*)				
*For any of the services below, please contact JCALPRO at 617.954.2345.				
Lighting Fixtures	QTY	Discount Rate	Standard Rate	Total Due: \$
Source 4 Par – (575 watt, 750 watt)		\$41.00	\$49.00	
Source 4 Leko – (575, 750 watt)		\$52.00	\$62.00	
Par 64 (1000 watt)		\$36.00	\$42.00	
Lighting Kits	QTY	Discount Rate	Standard Rate	Total Due: \$
Small Lighting Kit		\$215.00	\$259.00	
Medium Lighting Kit		\$378.00	\$455.00	
Large Lighting Kit		\$524.00	\$629.00	
X-Large Lighting Kit		\$641.00	\$769.00	
Dimmer Racks & Lighting Controls	QTY	Discount Rate	Standard Rate	Total Due: \$
Dimmer Control 1.2 x 4		\$94.00	\$112.00	
Dimmer Control 2.4 x 12		\$174.00	\$210.00	
Dimmer Control 2.4 x 24		\$372.00	\$448.00	
Total Due: \$				

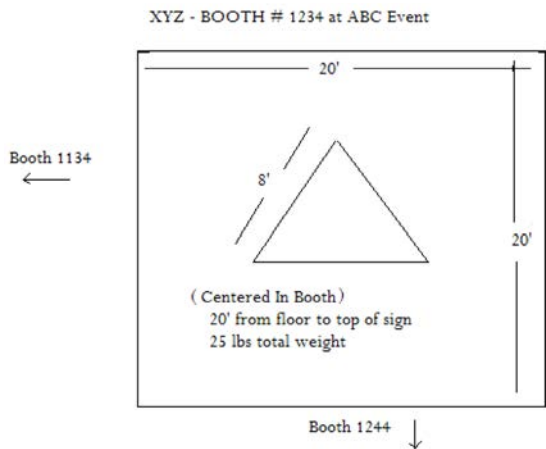

We require diagrams and booth layouts for all rigging and lighting orders. See sample on left.

SIGNATURE

To pay with a Discover, MasterCard, Visa or American Express, you may order online at www.signatureboston.com.
 To pay with a check, send a check payable to Massachusetts Convention Center Authority and this form to:

EXHIBITOR SERVICE CENTER | MASSACHUSETTS CONVENTION CENTER AUTHORITY | 415 SUMMER STREET | BOSTON, MASSACHUSETTS 02210
 617.954.2230 EXHIBITORSERVICES@SIGNATUREBOSTON.COM TAX ID#: 042768982

FOR MCCA USE ONLY			
Date Received:	Received by:	Check Number:	Discover/MC/Visa/Amex:



**Exhibitor Order Form
Plumbing Services**

Effective January 1, 2021

By submitting this order form, Exhibitor acknowledges and accepts all Policies, Terms & Conditions for service as set forth in the MCCA Exhibitor Ordering Guide available at <http://www.signatureboston.com/bcec/bcec-ordering-guide.aspx>.
To qualify for discount rate, request and payment must be received 21 days prior to show/event opening.

Incomplete information will delay processing.

Event or Show:		Booth no. (s)			
Event or show date(s):		Exhibiting firm:			
Billing address:	City:	State:	Zip:	Country:	
Phone:		Email:			
Ordered by/title:		Show site contact:			
Date:		Contact phone:			

WATER AND DRAIN SERVICES

Service	Description	QTY	Size	Discount Rate	Standard Rate	Total Due: \$
Water Approx 75 PSI Up to 3/4" line	Individual Connection			\$345.00	\$440.00	
	Additional Connection			\$205.00	\$255.00	
Drain Up to 3/4" line	Individual Connection			\$345.00	\$440.00	
	Additional Connection			\$190.00	\$235.00	
Fill & Drain	0-100 Gallons			\$180.00	\$220.00	
	Each additional 500 gallons			\$115.00	\$155.00	

SINK RENTALS

Service	Description	QTY	Size	Discount Rate	Standard Rate	Total Due: \$
Cold Water Sink Rental	Includes: sink, one water and one drain connection			\$705.00	\$870.00	
Small Hot & Cold Water Sink Rental	Includes: sink, hot water heater (6 gallon cap.), dedicated power, 2 water and one drain connection			\$940.00	\$1,165.00	
Large Hot & Cold Water Sink Rental	Includes: 3-tub basin, hot water heater (6 gallon cap.), dedicated power, 2 water and one drain connection			\$1,165.00	\$1,465.00	

COMPRESSED AIR AND GASSES*

Service	Description	QTY	Size	Discount Rate	Standard Rate	Total Due: \$
Air Approx 110 PSI	Individual Connection			\$430.00	\$530.00	
	Additional Connection			\$220.00	\$275.00	
CO2	20 lb Cylinder (Dry or Liquid)			\$180.00	\$215.00	
	50 lb Cylinder (Dry or Liquid)			\$200.00	\$235.00	
Nitrogen	300 ft3 Tank (Dry)			\$240.00	\$290.00	

SIGNATURE _____

Total Due: \$

To pay with a Discover, MasterCard, Visa or American Express, you may order online at www.signatureboston.com.
To pay with a check, send a check payable to Massachusetts Convention Center Authority and this form to:

EXHIBITOR SERVICE CENTER | MASSACHUSETTS CONVENTION CENTER AUTHORITY | 415 SUMMER STREET | BOSTON, MASSACHUSETTS 02210
617.954.2230 EXHIBITORSERVICES@SIGNATUREBOSTON.COM TAX ID#: 042768982

FOR MCCA USE ONLY

Date Received:	Received by:	Check Number:	Discover/MC/Visa/Amex:
----------------	--------------	---------------	------------------------

**Exhibitor Order Form
Security Services**

Effective January 1, 2021

By submitting this order form, Exhibitor acknowledges and accepts all Policies, Terms & Conditions for service as set forth in the MCCA Exhibitor Ordering Guide available at <http://www.signatureboston.com/bcec/bcec-ordering-guide.aspx>.
To qualify for discount rate, request and payment must be received 21 days prior to show/event opening.

Incomplete information will delay processing.

Event or Show:		Booth no. (s)			
Event or show date(s):		Exhibiting firm:			
Billing address:	City:	State:	Zip:	Country:	
Phone:		Email:			
Ordered by/title:		Show site contact:			
Date:		Contact phone:			

SECURITY SERVICES						
Date	# Of Officers	Scheduled hrs. (4 hr. min.)	Total Man hrs.	Discount Rate (per man hrs.)	Standard Rate (per man hrs.)	Total Due: \$
				\$32.00	\$38.50	
				\$32.00	\$38.50	
				\$32.00	\$38.50	
				\$32.00	\$38.50	
				\$32.00	\$38.50	
				\$32.00	\$38.50	
				\$32.00	\$38.50	
				\$32.00	\$38.50	
				\$32.00	\$38.50	
				\$32.00	\$38.50	
				\$32.00	\$38.50	
				\$32.00	\$38.50	
				\$32.00	\$38.50	
			Total Man Hours:			Total Due: \$

SIGNATURE _____

 To pay with a Discover, MasterCard, Visa or American Express, you may order online at www.signatureboston.com.

To pay with a check, send a check payable to Massachusetts Convention Center Authority and this form to:

 EXHIBITOR SERVICE CENTER | MASSACHUSETTS CONVENTION CENTER AUTHORITY | 415 SUMMER STREET | BOSTON, MASSACHUSETTS 02210
 617.954.2230 EXHIBITORSERVICES@SIGNATUREBOSTON.COM TAX ID#: 042768982

FOR MCCA USE ONLY			
Date Received:	Received by:	Check Number:	Discover/MC/Visa/Amex:

Exhibitor Guidelines, Information and Regulations

EXHIBITOR PARTICIPATION REGULATIONS

ACCESS CONTROL AND CREDENTIALING

Exhibitors accessing the BCEC – including exhibitors traveling to the BCEC, unloading exhibitor-related cargo and parking at the BCEC – must be credentialed by the BCEC Public Safety Department before entering the facility. Issued Exhibitor Credentials must be worn on the outermost garment (or on the right wrist if an ID band is issued) of the exhibitor (employees and contractors) at all times while inside the facility.

Exhibitors should check in with the General Service Contractor (GSC) Marshalling Lot Trailer, or go directly to the South Parking Lot if directed by the GSC or Licensee, before proceeding into the building at Southwest Badging. Upon request and as a requirement to be issued a MCCA ID, all employees and contractors working within an MCCA facility must identify themselves with a current and valid, government-issued photo identification (preferably a valid state-issued motor vehicle operator's license). Once positively identified by MCCA Public Safety, the exhibitor will be referred to the Licensee in order to register and receive event credentials.

ESCA identification badges are required for all General Service Contractors (GSC). Temporary MCCA credentials will not be issued to GSC employees and they will be turned away.

Lost/missing credentials must be reported to, and recorded by, MCCA Public Safety. The MCCA, in its sole discretion, reserves the right to revoke credentials for violations of law, facility policies and procedures, and/or injuries against persons or property, and/or when the revocation of those credentials is in the best interests of the MCCA.

AFFIXING TO THE FACILITY STRUCTURE

The MCCA does not allow exhibitors to:

- Rig cable/hanging devices or affix any materials to the ceiling, electrical buss ducts and conduits, sprinkler pipes, ventilation equipment, windows, columns or any other physical structure at the BCEC
- Cause or permit any nails, staples, hooks, tacks, screws, or the like to be driven into the facility structure (including, but not limited to, any wall, ceiling, column, stone, window, drape, painted, carpeted or concrete surfaces of the premises)
- Erect any decorations or use adhesive materials, including tape that can deface the walls, ceilings, floors, facilities and equipment contained on the premises
- Paint or permanently cover walls, floors, ceilings, or other areas of the facility or its furnishings or fixtures

BOOTH SET-UP AND DISMANTLE

The unpacking, assembling, dismantling and packing of displays and equipment may be done by full-time employees of an exhibiting company. Exhibitors are allowed to set-up and/or dismantle their own booths, provided that they use their own bona fide, full-time employees. It is acceptable for exhibitors to safely use power tools to set-up and/or dismantle their own booths.

No one under the age of 18 is permitted on the loading docks, in truck bays or in the loading dock yard. Additionally, no one under the age of 18 is permitted in the exhibit halls during move-in or move-out operations. The Licensee will determine age restrictions, if any, for hours when the exhibit hall is open for attendees.

BOOTH STAGING

1. In addition to equipment and furniture placed within a booth space, subject to show management limitations, exhibitors are allowed to stage the following items:
 - a. Boxed or loose product, materials or literature
 - b. Fiber cases used to ship pop-up displays
 - c. Personal items such as luggage, purses, briefcases or coats
2. The following restrictions must be observed when staging these additional items:
 - a. The amount of product, materials or literature that may be staged within a booth space must not exceed a one-day supply.
 - b. Items may be placed either in a display case, on a counter, on a shelving unit, in a closet, on a table, under a table or stacked neatly within the booth space.
 - c. Items that are stacked must not create a tripping hazard or hamper easy movement within the booth space.
 - d. Items may not be placed on or within six inches of floor ports, electrical wiring or cabling.
 - e. Pallets, empty crates, cartons and boxes may not be stored in the booth space.
 - f. Staging will not be allowed behind the back wall of the booth and behind the drape within the booth or exhibit area.

CABLING

No cables (Internet, electrical, audio, video, etc.) should be run in front of any doorways at any time. If cables must cross a doorway, cables must be flown — cable trays are not an acceptable substitute.

CANDLES

Candles are not permitted.

CAUTION TAPE

Use of 'Caution Tape' is prohibited. Yellow or red plastic tape with black stripes, or printed with 'Caution,' 'Do Not Enter' or other warning messages may only be placed by the MCCA to warn individuals of a hazardous condition. The MCCA prohibits the use of yellow or red plastic tape to restrict access to an event or exhibit display. Rope and stanchion is available from the General Service Contractor.

COOKING DEMONSTRATIONS

If cooking or heating appliances will be used, the MCCA prefers they are powered by electricity, use UL listed/approved equipment and be adequately ventilated.

An exhibitor may use butane for cooking purposes with prior approval of the MCCA Public Safety Department. Quantity inside the facility is limited to: two (2) 1-pound UL listed/approved non-refillable canisters per cooking device; one canister attached to the cooking device; and one spare canister. To prevent excessive amounts of butane within the facility, exhibitors may only use butane canisters purchased directly through the MCCA's exclusive food provider, Levy Restaurants.

Single-well cooking equipment (deep fryer type device) using combustible oils and solids shall:

1. Have lids available for immediate use
2. Be limited to 288 sq. in. (.19 sq. m) of cooking surface
3. Be placed in noncombustible surface materials
4. Be separated from each other by a minimum horizontal distance of 2 ft. (61 cm); multiple single-well cooking units may be placed together if the aggregate cooking surface does not exceed 288 sq. in. (.19 sq. m)
5. Be kept a minimum horizontal distance of 2 ft. (61 cm) from any combustible material

Exhibitor must provide a UL listed/approved fire extinguisher no less than 30 feet (9.15 meters) from the cooking device.

Exhibitor shall provide a 6 liter, Class K fire extinguisher for hazards where there is a potential for fires involving combustible cooking media (vegetable oils, animal oils or fats in cooking appliances) for each device.

Fire extinguishers must be mounted in a visible location and accessible at all times. All extinguishers shall be currently inspected and tagged by a licensed fire extinguisher company.

Open flames, cooking or other sources of heat are prohibited under any tent, canopy or tarp.

EXCLUSIVE SERVICES

The MCCA will be the exclusive provider of the following services: food & beverage, electrical, business center, Internet, rigging, the operation of ground-supported crank-ups, the operation and provision of lifts for theatrical purposes, plumbing, the use of the house sound system, and the supply of compressed airs and gases.

The MCCA is the preferred provider of security booth coverage for exhibitors. If your event designates another security vendor for booth coverage, you may choose to order through the event's preferred provider as detailed in your exhibitor kit.

EXHIBITOR PRODUCT

Exhibitors are prohibited from offering or selling any product(s) to any employee, agent, contractor or subcontractor working at the MCCA.

At the conclusion of the event, all products must be either:

- Removed from MCCA facilities by the exhibitor;
- Properly disposed of;
- Donated to a previously identified nonprofit organization; or
- Sold to an established business, with sales receipts supplied and produced on demand.

Any MCCA employee, agent, contractor or subcontractor working in MCCA facilities who is determined to be removing and/or accepting event-related product(s) is subject to immediate termination of employment or prohibition from working at all MCCA facilities.

All persons, vehicles, bags, containers, etc. are subject to search.

FIRE SAFETY REGULATIONS

Exhibits and decorative materials must meet the requirements of the Code of Massachusetts Regulations – 780 CMR EIGHT EDITION (Building Code). The Massachusetts Department of Public Safety (DPS) has jurisdiction over all safety matters of the MCCA. The DPS, in conjunction with the City of Boston Fire Department (BFD), provide guidance to the MCCA for a safe venue for all guests and employees at our facilities.

Prior to the show opening or at any time during the event, the MCCA Public Safety Department or other agency may inspect booths and other assembly areas to ensure these requirements are met. If they are not, adjustments can be costly – if a display is determined to be a hazard it may be ordered removed from the facility at the exhibitor's expense.

These requirements shall apply whether the event is open or closed to the public. The below topics are the minimum fire safety requirements for all events and are designed to provide an overview; the MCCA Public Safety Department reserves the right to make any final decision for life safety issues. Our sole effort is to ensure the success of your event and safeguard the safety and experience of all our visitors.

FIRE SAFETY LIMITATIONS

The following limitations apply to all exhibits located in the exhibition halls in the BCEC:

1. The following items are fire hazards and are prohibited for use in the BCEC:
 - a. Compressed flammable gases. Exception: Butane for cooking purposes with prior approval of the MCCA Public Safety Department (see Cooking Demonstrations)
 - b. Pyrotechnics, flammable/combustible liquids, hazardous chemicals/materials, blasting agents and explosives
 - c. Cut Christmas trees, cut evergreens or similar trees
 - d. Fireplace logs, charcoal and similar materials
 - e. Untreated mulch and Spanish moss or similar vegetation
 - f. Untreated hay or straw
2. Any interior finish, either permanent or temporary, will be required to meet the requirements of the Code of Massachusetts Regulations – 780 CMR EIGHT EDITION (Building Code).
3. The following rules apply regarding flame-retardant treatments:
 - a. All curtains, drapes, banners, decorations and acoustical material (including but not limited to cotton, hay, paper, straw, moss, split bamboo and wood chips) must be flame-retardant treated to the satisfaction of the Massachusetts Department of Public Safety. Material that cannot be treated for flame retardancy shall not be

used. The GSC or individual exhibitor must have on-site a copy of the Certificate of Flame Resistance for all floor covering, curtains and rigged signage. The use of carpet on walls, ceilings, seating products or as decorative material is prohibited.

- b. Combustible materials, an inch or more in thickness, glass or asbestos cloth may be used without flame-retardant treatment.
 - c. The use of oilcloth, tarpaper, sisal paper, nylon, Orlon®, and certain other plastic materials that are not flame-retardant is prohibited.
4. Open flame devices may be permitted when they are a necessary part of the exhibit, with prior approval of the MCCA Public Safety Department. Devices must be isolated from attendees by either four (4) feet or a barrier; be placed on a non-combustible surface; be separated from other devices by five (5) horizontal feet; and have a 10 lb. ABC fire extinguisher present within the exhibit. Fire extinguishers must be mounted in a visible location and be accessible at all times. All extinguishers shall be currently inspected and tagged by a licensed fire extinguisher company.
 5. The hanging or rigging of signs, displays or banners, etc. shall not interfere with the building fire sprinkler system.
 6. Exhibitors are prohibited from covering displays with drop cloths, sheets, table cloths or other non-flame resistant material.
 7. Storage of combustible materials in meeting rooms, ballrooms or service corridors is prohibited.
 8. Exhibitors shall move, remove or arrange with the General Service Contractor to remove wooden pallets, shipping crates, cardboard boxes and other packing materials from the exhibit hall area as soon as possible. These items are not permitted in the exhibit halls during events. See Booth Staging.

EXHIBIT HALL LIFE SAFETY EQUIPMENT

Fire extinguishers are located on each of the support columns in the exhibit hall area and on the perimeter walls. All brackets are 40 inches (102 cm) from the floor. Support column fire extinguishers are primarily mounted on the northwest quadrant. Fire extinguishers on the support columns along the north end of Hall A, and those on the south side of the air walls, are mounted on the southwest quadrant. General Service Contractors (GSC) and exhibitors are required to

maintain a minimum unobstructed path of no less than 48 inches (122 cm), 24 inches (61 cm) on center for fire extinguishers.

Fire extinguishers shall not be removed or temporarily relocated by any exhibitor, the Licensee or the GSC. The GSC is responsible for ensuring that egress paths, emergency exits, fire extinguishers, fire pull stations, fire department value boxes, fire alarm flashers and AEDs are not obstructed or obscured from view at any time in the facility. Anyone found responsible for moving, removing or blocking fire safety equipment is subject to a fine.

FLAME-RETARDANT TREATED MATERIALS

The following rules apply regarding flame-retardant treatments:

1. All decorations, drapes, signs, banners, acoustical materials, hay, straw, moss, split bamboo, plastic cloth, and similar decorative materials shall be flame-retardant to the satisfaction of the Boston Fire Department and State Fire Marshal.
2. Combustible materials, 3/8 inch or more in thickness, glass or asbestos cloth may be used without flame-retardant treatment.
3. The use of oilcloth, tarpaper, sisal paper, nylon, Orlon®, and certain other plastic materials that are not flame-retardant, is prohibited.
4. Table coverings used in exhibit halls must be flame-retardant treated, unless they lie flat, and have an overhang of no more than six (6) inches.
5. All materials must be certified by the Boston Fire Department within six (6) months of the event. The Boston Fire Department does not accept certificates from other jurisdictions. Materials may be sent directly to the Boston Fire Department for testing.
6. The City of Boston Fire Code prohibits the use of:
 - Fabric attached to a ceiling or used to cover any portion of an exhibit
 - Carpet on ceilings, walls, seating products, or as decorative material

LASERS

The use of lasers for exhibit demonstrations or visual effects for entertainment must be approved by the Licensee and the MCCA Public Safety Department. All lasers must comply with Code of Massachusetts Regulations 105 CMR 120.000, and be registered and approved by the Massachusetts Department of Public Health. Regulations and applications are available from the Massachusetts Department of Public Health.

FOOD & BEVERAGE SAMPLES

The MCCA prohibits any food or beverages from being brought into the building, except by Levy Restaurants, the exclusive food & beverage service provider. The distribution of food and beverages, regardless of type and/or quantity, is the sole responsibility of Levy Restaurants.

Levy Restaurants is the official caterer for all food and beverage services within the BCEC. All arrangements for the service of food and/or beverages must be made through the catering office. Food and beverage sampling in conjunction with specific exhibits may be permitted, but only to the extent approved in writing, in advance, by a Levy Restaurants Catering Sales Manager.

In order to obtain authorization from your Catering Sales Manager to distribute food and beverage items, one of the following conditions must exist:

- (1) The party interested in distributing food and/or beverage must be the manufacturer of said product. The interested party must only distribute sample sizes (2 ounces of pre-packaged food items or 4 ounces of non-alcoholic beverages) of his/her product, and cannot participate in cash sales of said product during the show.

-OR-

- (2) The party interested in distributing food and/or beverage items must pay a fee, which is based on a percentage of retail pricing for the item and is subject to all applicable administrative fees and taxes, in order to waive its right to exclusivity under the MCCA/BCEC License Agreement.

If a party brings unauthorized food and/or beverage items into the BCEC and does not subsequently meet one of the conditions listed above, the party must immediately remove the unauthorized item(s) from their exhibit or meeting space.

Temporary Food Service Permit Application

The City of Boston Inspectional Services Division requires a temporary food service permit for any food & beverage served at the BCEC that is not sourced through Levy Restaurants. Permit fees begin at \$30.00 for a one-day permit, with \$5.00 for each additional day of sampling (example: a 3-day permit costs \$40.00).

GLITTER, CONFETTI, POPCORN AND OTHER MATERIALS

The use of glitter, confetti, sand, popcorn or simulated snow types of material is not permitted in the BCEC. Additionally, adhesive-backed decals may not be given away or utilized.

GRATUITIES POLICY

It is against the MCCA's policy for any employee or service contractor to accept gratuities or gifts from the Licensee and/or any exhibitors. Offering of tips and gratuities to personnel employed by the MCCA, or its contractors, agents or suppliers, is not necessary and strictly prohibited. If you are approached or solicited by any MCCA or service contractor personnel for gratuities, please report this violation to the Chief of Public Safety at 617.954.2222.

GUARDRAILS AND STAIRS

Any platforms exceeding 30" in height will require a Massachusetts State building code compliant guardrail system. The guardrail shall be 42" in height, with balusters or solid material such that a sphere with a four-inch (4") diameter cannot pass through any opening.

The guardrails shall not have an ornamental pattern that would provide a ladder effect. This includes a guardrail on stairs.

The guardrail system shall be capable of withstanding a load of 200 pounds (minimum).

Stair construction shall meet Massachusetts State building code for riser height of 7" maximum and a tread depth of 11" minimum. These stairs shall have a handrail that shall be continuous, without interruption by newel posts, other

structure elements or obstructions. Handrails shall not be less than 34” or more than 38”. The handrail ends shall be returned to a wall or post. All stairway handrails shall have a circular cross section with an outside diameter of at least 1-1/4” and not greater than 2”.

Stair width shall be a minimum of 36”. Many multi-level displays are designed without risers, which is not permitted by the Massachusetts State building code as the stairway is part of a means of egress. The easiest way to address this issue with minimal cost is to secure a fitted piece of fire-rated plywood or sheet rock between the stringers against the back of the treads.

HAND-CARRY POLICY

The MCCA reserves the right to restrict all freight and package deliveries to the loading dock. MCCA Public Safety personnel will be on site to direct and assist exhibitors during move-in and move-out.

For the convenience and safety of exhibitors and patrons, all freight and material handling must enter and exit the facility through the loading dock. The Licensee and its exhibitors will be allowed to hand carry one item, one time, in or out of the facility without having to access the loading dock. (Hand-carried freight is defined as one item that can be easily carried by an individual, without the need for dollies or other mechanized equipment.)

No parking is allowed at the entrance of the facility, and the use of passenger elevators for movement of freight is not allowed. All packages are subject to inspection by facility personnel.

This policy is strictly enforced at The Westin Boston Waterfront Hotel skybridge as well.

LIGHTS

Only Underwriters Laboratories (UL) approved, clamp-on types of portable spotlights are allowed. All display lights must be turned off when the exhibitor leaves for the day. Only UL approved extension cords 12 gauge or greater, rated for 20 amp, are allowed. Note: Household extension cords are not permitted. These are generally 14 or 16 gauge and only rated at 15 amp.

MATERIAL HANDLING

Exhibitors are allowed to perform their own material handling, providing all of the following criteria are met:

- Exhibit personnel performing the work must be bona fide, full-time employees (“authorized personnel”) of said company.
- Exhibitors may choose to off-load from a company-owned truck or rental vehicle, or from a car, van or truck owned by personnel of the company provided the vehicle is co-owned or rental vehicles must be less than 24 feet in length.
- Exhibitors may use only hand-operated equipment, which they have provided; two-wheeled hand trucks and four-wheeled flat trucks are permitted as well.
- At no time can vendors (A/V, furniture design firm, etc.) unload their items. An approved General Service Contractor (GSC) or the Exclusive Rigging Service Provider (ERSP) must be hired by the Licensee to unload/re-load and push in all vendors.

MEANS OF EGRESS

The travel distance within an exhibit booth or exhibit enclosure (including temporary office/meeting spaces) to an exit access aisle shall not exceed 50 feet (15 meters). There should be a minimum of two (2) separate exits from any point in the hall or room where the occupant load is less than 500 persons. Where occupant loads are between 500 and 999 persons, there shall be a minimum of three (3) separate exit doors. Where occupant loads are 1,000 persons or greater, there shall be a minimum of four (4) separate exit doors.

Exits must be so located and exit access arranged so that exits are readily accessible at all times. Where more than one exit is required, exits must be remotely located from each other and arranged and constructed to minimize any possibility that more than one may be blocked by a fire or other emergency condition.

Where exits are not immediately accessible from an open floor area, safe and continuous unobstructed passageways, aisles or corridors leading directly to every exit must be maintained and arranged, to provide access for each occupant to at least two exits by separate ways of travel. At no time should an exit door or exit access door be locked, blocked or obstructed in a manner that will confuse or slow the movement of any people within the area. This requirement will also be in effect during the “move in” and “move out” of events.

During certain events, the total occupancy of larger meeting rooms and the ballrooms meeting room(s) being used may not require all the exit capacity provided for that area. In these cases, a special review will be done on the request to close some of the exit doors. An explanation, along with detailed drawings showing these doors, must be submitted for approval. If approved, the doors and exit signs must be covered to prevent any confusion to the occupants.

MULTI-LEVEL BOOTHS AND CEILINGS/CANOPIES

Guidelines for Covered Exhibits With Less Than Three Hundred (300) Covered Square Feet

All materials used in the construction of covered exhibits and all decorative materials within the exhibit must be non-combustible or limited combustible (flame-retardant) materials. Certification of flame retardant treatment, along with samples of said materials, must be submitted, if requested by the MCCA Public Safety Department or the Massachusetts Department of Public Safety. It is strongly recommended that certifications of flame retardant treatments be available at show site to avoid on-site testing of materials.

Fabric must pass the NFPA-701 Code for flame spread and smoke development - Class A, Flame Spread less than or equal to 25, Smoke Developed less than or equal to 450. Canopies and tarps must be fire resistant and meet CPAI 84 (Canvas Products Association International) specifications. The original flame retardant compliance tag must be attached to tent, canopy or tarp.

The use of tents inside the Convention Center requires a special permit from the Massachusetts Department of Public Safety. Please contact the MCCA Public Safety Department at 617.954.2222 for assistance.

Exhibitor must install a single station and battery operated smoke detector on the interior of each covered exhibit or structure, including enclosed storage closets, regardless of the square footage. The detector must sound an audible alarm and be installed per the manufacturer's instructions.

Exhibitor must provide at least one (1) 10 lb. ABC, dry chemical fire extinguisher. Fire extinguishers must be mounted in a visible location and accessible at all times. All extinguishers shall be currently inspected and tagged by a licensed fire extinguisher company.

A single exhibit or group of exhibits with ceilings that do not require sprinklers shall be separated by a distance of not less than 10 feet (3050 mm) where the aggregate ceiling exceeds 300 square feet (28 square meters).

Open flame, cooking or other sources of heat are prohibited under any tent, canopy or tarp.

MOVE-IN PROCEDURES

All exhibitor move-in is restricted to the BCEC Loading Dock. No exhibitor will be allowed access with his or her move-in materials via any other entrance to the facility. Please note the hand carry rule within the Exhibitor Participation Rules/General Conditions Section of the Event Guide.

MULTI-LEVEL BOOTHS AND CEILINGS/CANOPIES

Guidelines for Multi-level Exhibits (regardless of the size) and Covered Exhibits With Larger Than Three Hundred (300) Covered Square Feet

Requests for construction of multi-level exhibits (regardless of the size) must be authorized by show management before being reviewed by the MCCA Engineering and Maintenance Division and MCCA Public Safety Department. To ensure the success of your exhibit, please read and comply with the following guidelines:

1. Plans should be submitted a minimum of 90 days before the move-in date of the event and must adhere to the following:
 - a. They must be scaled, signed and dated by a registered architect or professional engineer.
 - b. They must include the show name and dates.
 - c. They must include exhibitor's name and assigned booth number.
 - d. They must include directional information (i.e. indicate neighboring aisles and/or booth numbers).
 - e. They must indicate maximum exhibit height, within the booth. Height guidelines are established, per event, by show management.
 - f. They must include connection details for the elevated floor and stairs, and permitted loading for furnishings, storage units, work surfaces or occupants who will be permitted access to the upper level.
 - g. They must include a floor loading schedule that identifies the maximum safe floor loading, fixture loads (dead loads) and occupant loading (live loads), establishing what shall be the effective limits.
2. All materials used in the construction of multi-level and/or covered exhibits and all decorative materials within the exhibit must be non-combustible or limited combustible (flame-retardant) materials. If requested, certification of flame-retardant treatment, along with samples of said materials, must be submitted to the Massachusetts Department of Public Safety for testing. It is recommended that certifications of flame retardant treatments be available at show site.

CONTINUED FROM PREVIOUS PAGE

MULTI-LEVEL BOOTHS AND CEILINGS/CANOPIES**Guidelines for Multi-level Exhibits (regardless of the size) and Covered Exhibits With Larger Than Three Hundred (300) Covered Square Feet**

3. Exhibits with an enclosed room or occupied second story must post notice at the bottom of the stairway, indicating maximum permitted occupancy (or total permitted weight load of the second level).
4. If second level is to be occupied and greater than three hundred (300) square feet, or is designed to hold 10 or more persons, two (2) stairways are required, remote from each other. If second level is to be occupied and less than three hundred (300) square feet, one (1) set of stairs is permitted.
 - a. Stair construction shall meet Massachusetts State building code for riser height of 7" maximum and a tread depth of 11" minimum.
 - b. These stairs shall have a handrail that shall be continuous, without interruption by newel posts, other structure elements or obstructions.
 - c. Handrails shall not be less than 34" or more than 38". The handrail ends shall be returned to a wall or post. All stairway handrails shall have a circular cross-section with an outside diameter of at least 1-1/4" and not greater than 2".
 - d. Stair width shall be a minimum of 36". Many multi-level displays are designed without risers, which is not permitted by the Massachusetts State building code as the stairway is part of a means of egress.
5. Individual areas of upper decks or covered areas must be limited to dimensions that do not exceed one thousand (1,000) square feet.
6. Exhibitor must install a single station and battery-operated smoke detector on the interior of each covered exhibit or structure, regardless of the square footage. The detector must sound an audible alarm and be installed per the manufacturer's instructions.
7. Exhibitor must provide a portable, dry chemical fire extinguisher for each level or each covered exhibit or structure. At least one (1) 10 lb. ABC portable type fire extinguisher must be provided for each three hundred (300) square feet. Fire extinguishers must be mounted in a visible location and accessible at all times. All extinguishers shall be currently inspected and tagged by a licensed fire extinguisher company.

AUTOMATIC FIRE EXTINGUISHING SYSTEM

1. The following shall be protected by an automatic extinguishing system:
 - a. Any home or house constructed within the exhibit hall; and it must also include smoke/fire alarms and a 10 lb. ABC fire extinguisher on each level
 - b. The lowest level of a multi-level exhibit, regardless of size, and/or a single-story covered exhibit where the covered area exceeds 300 sq. ft. (27.9 sq. m), and/or any covering over a multi-level exhibit exceeding 300 sq. ft. (27.9 sq. m)

Exception: Exhibitors installing these approved flame retardant materials as coverings may avoid the need to install a fire extinguishing system:

- A flame retardant material with fusible seams that under low temperatures (176° F / 80° C) will split and open the canopy to allow smoke to rise, activate sprinklers and allow water through the opening
 - A flame retardant open mesh material with a minimum 70% opening
 - Ceilings that are constructed of open grate design or listed dropout ceilings in accordance with NFPA 13, Standard for the Installation of Sprinkler Systems, shall not be considered ceilings within the context of this section
 - Vehicles, boats and similar exhibited products having over 100 sq. ft. (9.3 sq. m) of roofed area shall be provided with smoke detectors (Single station and battery operated or portable smoke detectors meeting the requirements for Household Fire Warning Devices in NFPA 74 are acceptable.)
2. A temporary sprinkler system must be connected to the Convention Center's domestic water system. The MCCA maintains a list of approved, state-licensed fire sprinkler companies authorized to install temporary fire sprinkler systems. The vendor must submit a sprinkler coverage plan to the MCCA Engineering & Maintenance Department for approval.
 3. To order a plumbing connection for the sprinkler system before you arrive, click on the "Exhibitor Online Ordering" link from the main MCCA Webpage (www.massconvention.com).

4. Exhibitor must install at least one (1) single station and battery operated smoke detector on the interior of each covered exhibit or structure regardless of the square footage. The detector must have an audible alarm and be installed per the manufacturer's instructions.
5. Exhibitor must provide a portable, dry chemical fire extinguisher for each level or each covered exhibit or structure. At least one (1) 10 lb. ABC portable type fire extinguisher must be provided for each three hundred (300) square feet. Fire extinguishers must be mounted in a visible location, and be accessible at all times. All extinguishers shall be currently inspected and tagged by a licensed fire extinguisher company.

The Massachusetts Department of Public Safety does not permit the use of a fire watch ordered in lieu of a temporary fire sprinkler system as an alternative method for fire safety compliance.

PROTECT YOUR EXHIBIT AND MATERIALS

The MCCA is not liable for, nor does the MCCA carry any insurance on, exhibitor property or fixtures. Please bear in mind that all of your exhibit material and displays are your property. Therefore, it is important that you take every precaution to protect this material. Below are some suggestions toward this end:

1. Ship your materials with a qualified carrier and be sure to lock trunks/crates.
2. If cartons are used, be sure that they are securely taped or banded and under no circumstances marked with the name or type of articles contained therein.
3. Be sure to furnish your shipping company with an accurate account and complete bill of lading.
4. Do not leave your booth unattended during the set-up period.
5. Do not leave exhibit material under tables or displays.
6. Do not include exhibit material in containers to be stored with empties.
7. At the close of the exhibit, be sure to pack as quickly as possible and under no circumstances leave your space unattended during this period.

8. If at all possible, have one of your staff remain in your space with your shipment, until it is actually picked up by the drayage contractor's personnel.
9. Promptly report any missing items or suspicious person(s) to Public Safety.

SMOKING

The BCEC is a non-smoking facility. Smoking of any tobacco product or electronic cigarette ("e-cigarettes") is NOT allowed in the building at any time. Designated smoking areas are located outside the building.

SOLICITATIONS

No solicitations or collections are permitted in the BCEC.

VEHICLES AND OTHER MOTORIZED EQUIPMENT

Vehicles that are to be brought into the BCEC must be pre-approved. In some cases, vehicles will not be allowed in the building, and there are restricted areas that vehicles cannot enter. Keys to start the vehicle, as well as any deactivation codes for security features, must be left with the Public Safety Department.

Motorized vehicles are defined as any vehicle that is propelled by an internal combustion engine, such as, but not limited to: automobiles, trucks, buses, farm equipment, construction equipment, motorcycles, snow mobiles, aircraft, watercraft and lawnmowers.

Motorized vehicles shall:

1. Be equipped with a locking (or taped) gas cap to prevent the escape of vapors. Fuel tanks shall not have more than three (3) gallons of fuel, or 1/8 tank, whichever is less.
 - a. Exceptions:
 - i. Recreational vehicles (RVs) may have up to 1/4 tank of fuel
 - ii. Aircraft that is on standby status and is required to have a minimal fuel level as determined by the Federal Aviation Administration (FAA) such as MedFlight®
2. Have at least one (1) battery cable used to start the engine, disconnected and the end of the disconnected battery cable, taped. It is preferred that the positive or "hot" cable be disconnected.

3. Not be moved during exhibit hours. Vehicles may not be started or operated within the exhibit hall for the first 15 minutes after the exhibit hall closes to the public for the day or final closing of the event. No vehicle may be operated on the exhibit hall without a lead person walking in front of the vehicle warning people of vehicle movement.
4. Fueling or defueling of vehicles is prohibited.

MCCA Services

The BCEC is the exclusive provider of the following services: food & beverage, business center, coat check, electrical, Internet, plumbing and the supply of compressed airs and gases, the use of the house sound system, rigging, the operation of ground-supported cranks-ups, and the operation and provision of lifts for theatrical purposes. Most of these services are available directly to an exhibitor and should be ordered through your Exhibitor Services Center. These exclusive services are subject to prices and conditions on appropriate order forms. Discounts may apply to some services by meeting the advance payment deadlines and conditions noted on the forms.

Exhibitors may order services through the Signature Boston Exhibitor Ordering Site at www.signatureboston.com. For more information, Exhibitor Services can be contacted at 617.954.2230 or exhibitorservices@signatureboston.com.

The MCCA is the preferred provider of security booth coverage for exhibitors. If your event designates another security vendor for booth coverage, you may choose to order through the event's preferred provider as detailed in your Exhibitor Kit.

ATMS

Guests will find ATMs on Level One in the North Lobby and the Wicked Good Market, and on Level o East.

AUDIO/VISUAL SERVICES

The BCEC offers in-house A/V services on a preferred basis, with a preferred audio/visual provider to help provide comprehensive event support and services. All types of audio and visual display devices, screens and computer interfaces are available, along with skilled operators. The BCEC features a digital audio system and extensive use of fiber optic cabling to distribute signals throughout the facility. The BCEC has a clear line of sight to all satellites and dedicated truck parking

spaces, complete with power and signal distribution. The preferred audio/visual provider is the exclusive provider for the use of the in-house sound systems. All other A/V companies must bring in a stand-alone speaker system.

BOOTH PACKAGES

Services cannot be resold or bundled as a package without prior written approval.

BUSINESS CENTER

The MCCA in-house vendor is the exclusive service provider of the Business Center. From simple documents to complex projects and on-going programs, the MCCA business center will provide document management solutions to meet your needs. The document solutions capabilities include: copying and digital printing, document production, supplies, computer services, electronic file submission, signage, custom printing services, document distribution, pack and ship options, express and ground service, fax service with delivery of incoming messages, and desktop/word processing.

SATELLITE SERVICES

The BCEC has a clear line of sight to all satellites and convenient parking spots for uplink and downlink trucks. Power and signal distribution is available at all truck locations. Please contact Exhibitor Services for more details and pricing.

Transportation

PUBLIC TRANSPORTATION

We strongly encourage you to promote public transportation as an efficient option for your attendees and exhibitors. Public transportation in the Boston area is provided by the Massachusetts Bay Transportation Authority (MBTA or "The T"). A number of excellent public transportation options are available for service to and from the BCEC. South Station, the premier regional transportation center, is a ten-minute walk from the front door of the BCEC. Services available at South Station include the MBTA's Red and Silver lines, Amtrak regional service, bus service, and commuter rail.

TAXI AND RIDESHARE INFORMATION

MMCCA staff will coordinate with the individual taxicab companies and the Boston Hackney Division for the needs of each event. Assigned staff will manage taxi service logistics. Level One, North Entrance at 415 Summer Street is the

required location for taxicab drop-off and pick-up. This taxi stand location will be separate from the other transportation operations for the event. MCCA Transportation staff will monitor the volume of taxis, and will request more from the taxicab companies as needed throughout the event.

Rideshare vehicles (such as Uber & Lyft, etc.) are only permitted to pick up and drop off at designated locations. These locations are event-specific, and will appear in the app when you open it to request a vehicle. Signs will be posted throughout the BCEC to direct you to the proper pick-up location.

PRIVATE CHARTER SERVICE

Any exhibitor wishing to pick up or drop off a private charter shuttle on-site must request a staging area from the MCCA Transportation Department. All requests must be made in advance by emailing MCCATransportationServices@signatureboston.com. Requests must include the name of the event, the date & time of the trip, name of the bus company, and number of vehicles being used.

Exhibitors may contract directly with the MCCA to provide charter services. Please email MCCATransportationServices@signatureboston.com to request a quote for services.

PARKING

The BCEC currently maintains 1,343 parking spaces in the South Parking Lot. There are also 200 parking spaces that are utilized for valet parking. Please keep in mind that there is no 24-hour parking or overnight parking at the BCEC. In-and-out privileges are only available to those who purchase Exhibitor Parking Passes (only offered for select events, please contact Exhibitor Services with any questions). Any vehicle left at the BCEC overnight is subject to tow at the owner's expense.

For larger events where the amount of parking available on-site is expected to be insufficient to meet the needs of a particular event, the MCCA Transportation Department will work with local parking lots and garages to create an overflow parking plan. Vehicles will be sent off-site, and attendees will be provided with either walking directions back to the BCEC or a shuttle depending on the distance of the parking lot from the BCEC.

Please note that during events where parking is expected to fill the MCCA will restrict parking on-site to single-spaced vehicles only. Exhibitors arriving with box trucks or vehicles with trailers in tow will be directed to park off-site, and will not be permitted into the South lot until the conclusion of the event.

PARKING ON LOADING DOCK

Exhibitor staff members parking on the loading dock and displaying their loading dock parking pass on the dashboard of the motor vehicle for the purpose of unloading cargo have a limit of 20 minutes in order to do so. Exhibitor staff remaining in the loading dock area beyond the 20-minute limit, and/or who do not properly display a valid loading dock parking pass, subject themselves to towing at the vehicle owner/operator's risk and expense.

ADA PARKING

There is an ADA area in the South Parking Lot, in the rear of the facility. Parking is available in these spaces for the same rate as standard self-parking. From there, there is a handicap-accessible sidewalk to Level Zero, where there is an entrance to the BCEC through the Southeast lobby.

Levy Restaurants BCEC Authorization Request

Sample Food and/or Beverage Distribution

Please complete this form to receive authorization to distribute food or beverages not purchased through Levy Restaurants. Levy Restaurants has exclusive food and beverage distribution rights within the Boston Convention & Exhibition Center (BCEC) and has the responsibility to the City of Boston to strictly regulate any food and beverage activity within the BCEC. Due to strict regulations, any vendor sampling product within the above mentioned parameters must submit a sampling form to Levy Restaurants for approval.

The Selling of Food and/or Beverage products by any other entity is strictly prohibited.

Sponsoring Organizations of expositions and trade shows, and/or their exhibitors, may distribute SAMPLE SIZE food and/or beverage products ONLY upon written authorization and adherence to ALL of the conditions outlined below.

GENERAL CONDITIONS - FOOD INDUSTRY RELATED SHOWS

1. Items dispensed are limited to products Manufactured, Processed or Distributed by exhibiting companies.
2. All items are limited to SAMPLE SIZE and must be dispensed/distributed in accordance to Local and State Health Codes:
 - a. Non-Alcoholic Beverages limited to maximum of 4 oz. Sample Size, served in biodegradable (or plastic) cups. No cans or bottles will be permitted.
 - b. Alcoholic beverage sampling is permitted only if you are the manufacturer or distributor of the beverage. Alcoholic beverages must be "sample" sizes (2 oz. for beer/wine, .25 oz for liquor) and can only be served by a licensed Levy Restaurants bartender.
 - c. Food items are limited to "bite size", not to exceed 2 oz. portions or a 2 oz. prepackaged samples.
 - d. All food/beverage items brought in are required by the Boston Health Department to have a temporary Health Permit. This includes prepackaged food samples, samples not intended for consumption on the show floor, and bottled water.
3. Vendors are responsible for all booth rental fees, electrical, plumbing, drayage and all other Levy Restaurants and/or BCEC services.

IF YOU DO NOT MEET THE CONDITIONS LISTED ABOVE, THE FOLLOWING POLICIES APPLY:

TAKE-AWAY ITEMS AND BUY-OUT FEES. Any Food and Beverage brought on premises without the written authorization from Levy Restaurants, the BCEC and [NAME Show] Management is strictly prohibited.

1. Take-away items will be assessed and approved on a case by case basis by Levy Restaurants. Take-away items are items that are distributed to attendees but are not intended for immediate consumption at the time of receipt. Requests for take-away items must be submitted no later than DATE.
2. Requests for all Food or Beverage Products brought on the premises for consumption at hosted banquet/ booth events or that do not fall within the Sampling parameters listed above may incur a Buy-out Fee by Levy Restaurants. An appropriate buy-out fee will be determined by Levy Restaurants on a case by case basis; however, the buy-out fee will be based on a percentage of the retail pricing for the food and/or beverage item and is subject to all applicable taxes and service charges.

UNUSED FOOD OR BEVERAGE PRODUCT that requires pick-up or shipment after the show/event is the responsibility of the Company that is sampling the product. Absolutely NO REFUNDS of Buy-out Fees will be given for Food or Beverage Product if not consumed during show/event.

FOOD AND BEVERAGE RELATED SERVICES including storage, delivery, or any other service required for Food and/or Beverage products brought from the outside are not the responsibility of and will NOT be provided by Levy Restaurants.

If these services are required the following charges will be assessed:

1. \$150.00 for a small visi cooler, per day
2. \$300.00 for a large double visi cooler, per day
3. \$25.00 per drop off and per pick-up for steward
4. \$150.00 per day minimum for dry or refrigerated storage, per pallet
5. \$6.00 per 5 pound bag of ice

Both the refrigerator and cooler require stewarding labor to drop off and retrieve the equipment. A security deposit of \$250 per piece of equipment will also apply.

SHIPPING/RECEIVING Please note that only product you expect to be prepared by, stored by and delivered by Levy Restaurants should be shipped to Levy Restaurants. Please see the Shipping Label, fill it out and ensure it is used properly to ensure proper receiving of your product. You must contact Levy Restaurants prior to shipping items – items not expected will not be received. For all Food and Beverage not purchased through Levy Restaurants, all standard fees mentioned above will be charged where applicable, including 20% Administrative Fee and Applicable Sales Tax.

The Company named below acknowledges they have sole responsibility for the use, servicing or other disposition of such items in compliance with all applicable laws. Accordingly, the firm agrees to indemnify and forever hold harmless Levy Restaurants and the BCEC from all liabilities, damages, losses, costs or expenses resulting directly or indirectly from their use, serving or other disposition of such items.

Exhibiting firm must provide Levy Restaurants with a Certificate of Insurance showing evidence of Commercial General Liability with an each occurrence limit of \$1,000,000 and naming Levy Premium Foodservice Limited Partnership and Massachusetts Convention Center Authority as additional insured. Information must be received no later than close of business (5:00 PM EST) on _____

Event or Show:		Event or show date(s):		
Exhibiting firm:		Booth no. (s):		
Billing address:	City:	State:	Zip:	Country:
Phone:		Email:		
Ordered by/title:		Show site contact:		
Date:		Contact phone:		

PLEASE SPECIFY: ITEM / DISTRIBUTION PURPOSE / QUANTITY / PORTION SIZE / METHOD OF DISPENSING

Before returning this document, please sign the “Agreed” indicating you have read and you agree with all conditions.

Agreed _____ Approved _____ Date _____
Exhibiting Firm Levy Restaurants

PLEASE RETURN FORM TO LEVY RESTAURANTS BY _____ TO ENSURE CONFIRMATION AND APPROVAL.

For additional services and information, please contact: Levy Restaurants | Exhibitor Catering Sales Department
 415 Summer Street | Boston MA 02210 | Tel. 617.954.2382 | Fax 617.954.2159

OVATION 

pri  med[®]

EXHIBITOR EQUIPMENT RENTAL INFORMATION

Pri-Med: East (Boston)

OVATION Inc. is pleased to be the vendor for your audio/visual needs at Pri-Med East, being held December 9th – 11th in Boston, MA at the Boston Convention & Expo Center. Below is a link to an online order form to select your required A/V equipment.

https://form.jotform.com/OVATION_Events/primed-east-exhibit-order

If you have any questions, please feel free to reach out to us at:
exhibitororders@ovationevents.com.





XPress Connect Family

Exhibiting success is much more than just purchasing a booth and showing up at the event. Meeting qualified prospects and turning them into loyal customers is the true measure of exhibiting success. CDS' XPress Connect lead retrieval equipment and programs are the keys to a highly productive onsite experience.

Top Features



Literature Fulfillment

Email links quickly with all the information customers and prospects request



Custom Qualifiers

Customize your qualifying questions and responses to build full prospect profiles



Instant Email Follow-up

Follow-up with hot prospects who visit your booth



Rate Leads

Identify top prospects and customers by assigning a rating



Schedule Appointments

Set up follow-up meetings with leads and close more deals



VIP Alerts

Receive a text alert when anyone you identify as a VIP enters your booth



Exhibitor Portal

Leads, analytics, instructions, and best practices online all the time

Risk-Free Refund Policy

If the show is postponed/canceled, you can request a refund by emailing xpressleadpro@cdsreg.com.

We will honor a full refund, less any processing fees incurred with your original order. Requests must be received within 90 days of the original show start date.

Order Today and don't miss a single lead:

www.xpressleadpro.com Showcode: **east1221**



Our full-featured lead retrieval system running on **YOUR** Apple or Android mobile device.



Full-featured lead retrieval system running on **OUR** large screen Android phone.

Connect Comparison

	App	Plus
Scan anywhere, any time	✓	✓
Custom qualifiers	✓	✓
Literature fulfillment	✓	✓
Real-time leads	✓	✓
Reporting portal	✓	✓
Instant email follow-up	✓	
Rate leads	✓	✓
VIP alerts	✓	✓
Schedule appointments	✓	
Add images to leads	✓	
Audio notes	✓	✓
Optional Bluetooth printer*	✓	✓
Online and offline modes	✓	✓